

# LEGA ORIGAMI

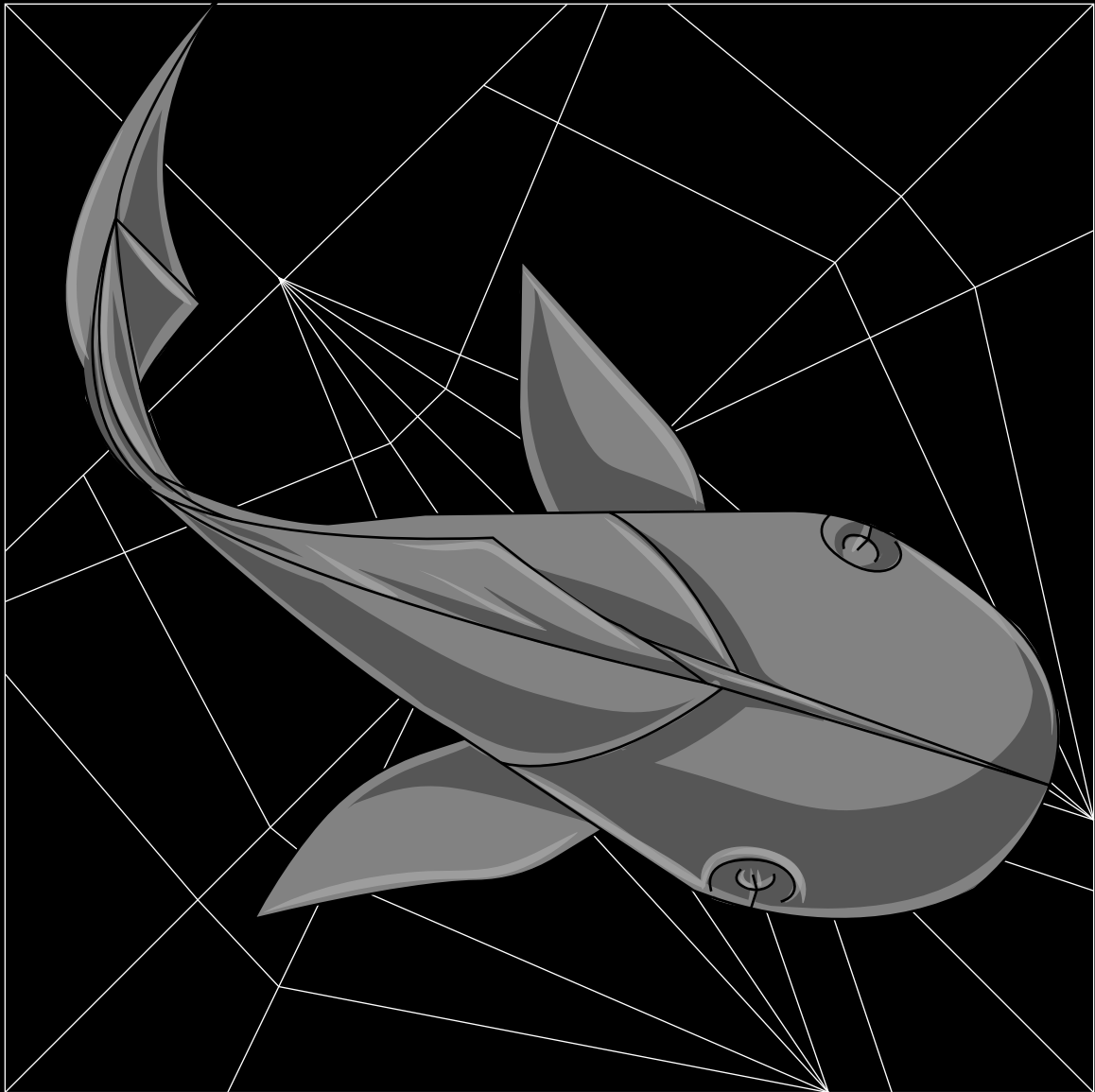

**KOI**



Livret N°3

**Koi :** ★★★★★

**Gilles Adrien Petit**

[www.Plegaorigami.com](http://www.Plegaorigami.com)  
[youtube.com/plegaorigami](https://youtube.com/plegaorigami)  
[facebook.com/plegaorigami](https://facebook.com/plegaorigami)



**Papier recommandé :**

Papier normal

**Taille recommandé :**

25x25 cm Minimum

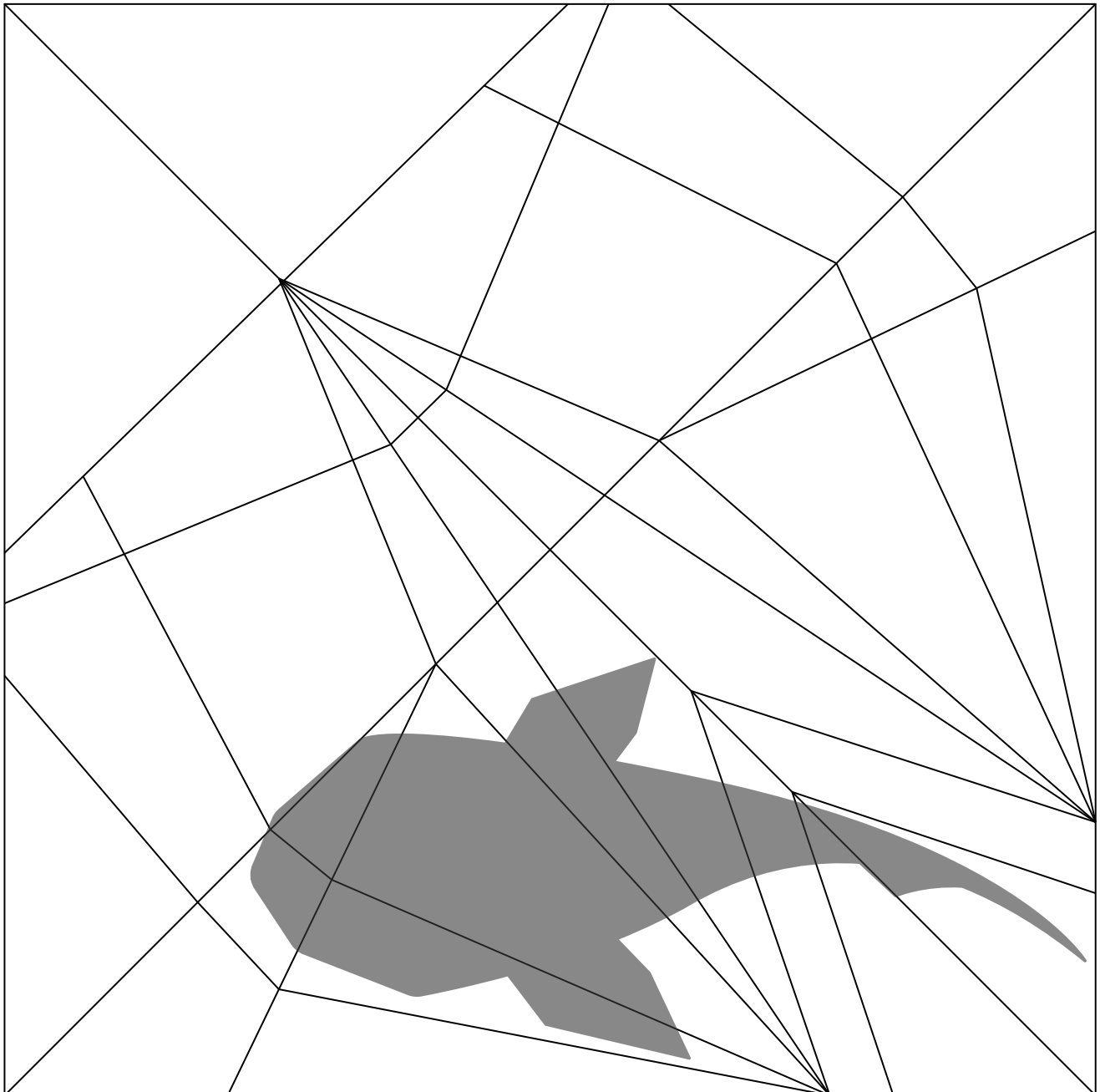
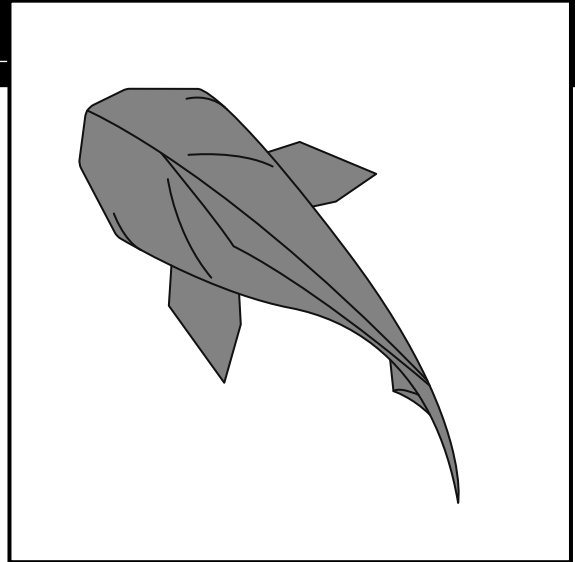

# Explications des symboles

**PLI VALLÉ** ..... - - - - -

**PLI MONTAGNE** ..... - - - - -

**PLIER DEVANT** ..... 

**PLIER DERRIERE** ..... 

**REPLI** ..... 

**PLIER ET DEPLIER** ..... 

**INSERER ; GLISSER DANS** ..... 

**TOURNER LE MODELE** ..... 

**GUIDER LA POINTE ; LE FUILLET** ..... 

**REPETER L'OPERATION  
AUTANT DE FOIS QU'IL Y A DE BARRES** ..... 

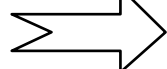
**DEPLIER** ..... 

**ENFONCER ; APUYER** ..... 

**VUE AGRANDIE** ..... 

**MAINTENIR CE POINT** ..... 

**MODELER ; DONNER DU VOLUME** ..... 

**SOUFFLER ; GONFLER** ..... 

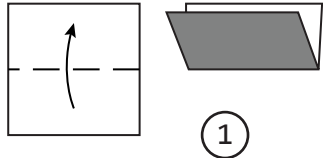
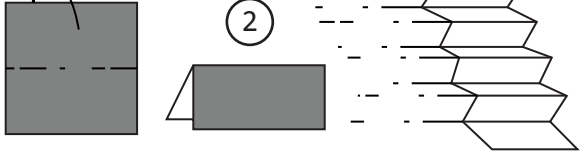
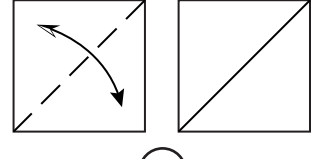
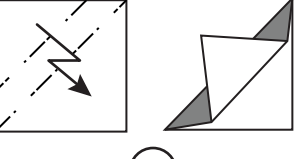
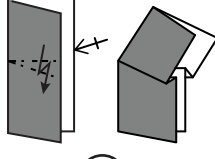
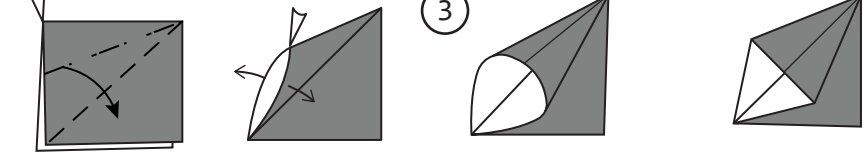
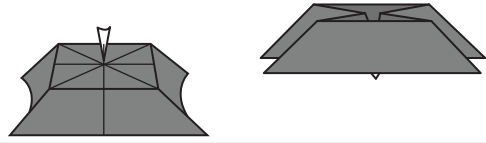
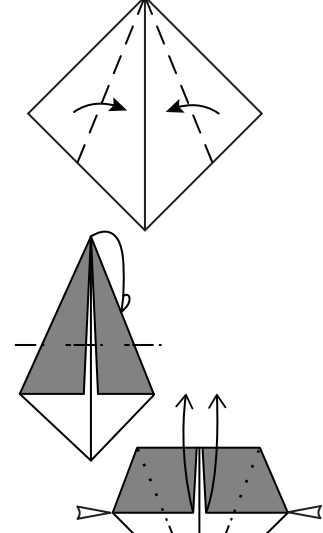
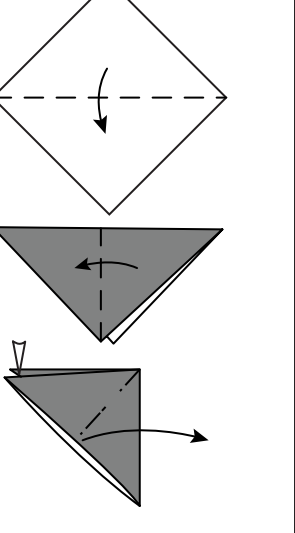
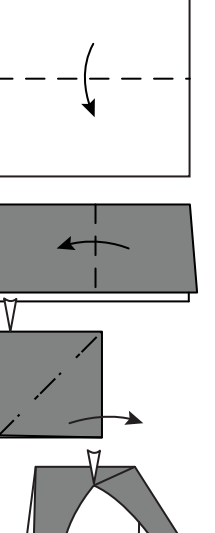
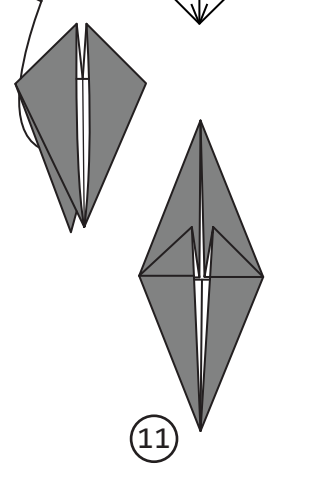
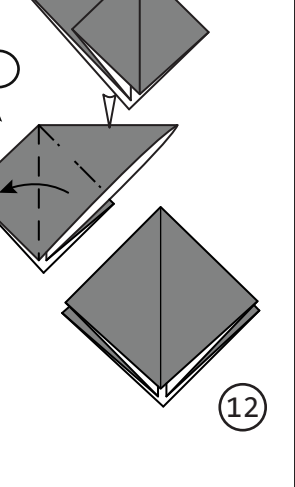
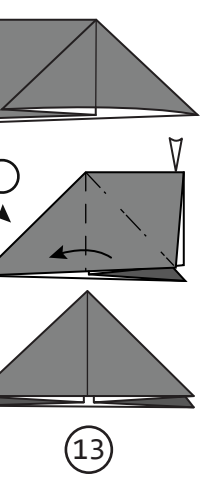
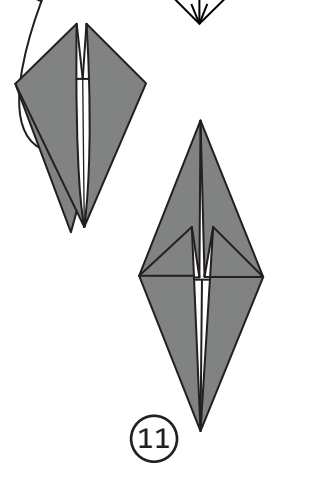
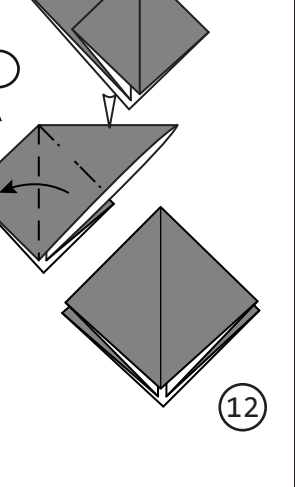
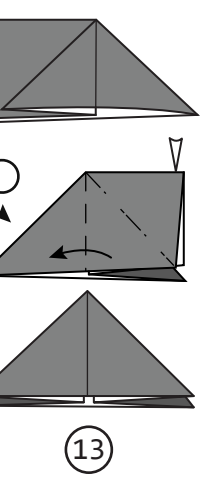

<p>1) PLI VALLÉE  2) PLI MONTAGNE  3) PLIER ; DEPLIER  4) REPLI  5) AUTRE TYPE DE REPLI  6) PLI APLATI  7) OREILLE DE LAPIN  8) PLI INVERSE INTERIEUR  9) PLI INVERSE INTERIEUR  10) PLI INVERSE EXTERIEUR</p>	 <p>1</p>	 <p>2</p>	
<p>7) OREILLE DE LAPIN</p>	 <p>3</p>	 <p>4</p>	 <p>5</p>
<p>7) OREILLE DE LAPIN</p>	 <p>3</p>	 <p>8</p>	
<p>9) PLI INVERSE INTERIEUR</p>	 <p>11</p>	 <p>12</p>	 <p>13</p>
<p>10) PLI INVERSE EXTERIEUR</p>	 <p>11</p>	 <p>12</p>	 <p>13</p>
<p>11) BASE DU POISSON  12) BASE PRELIMINAIRE  13) BASE DE LA BOMBE A EAU</p>	 <p>11</p>	 <p>12</p>	 <p>13</p>

*Tester les plis pour vous familiariser avec les symboles.*

**KOI:**

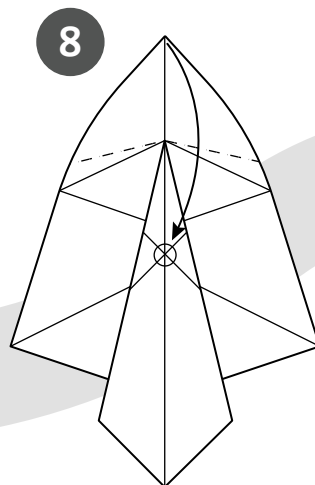
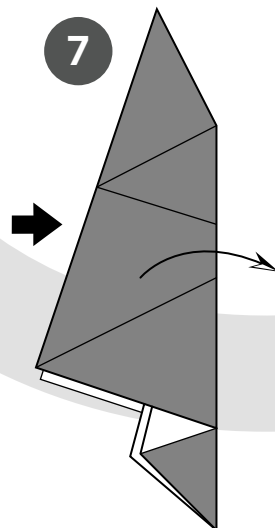
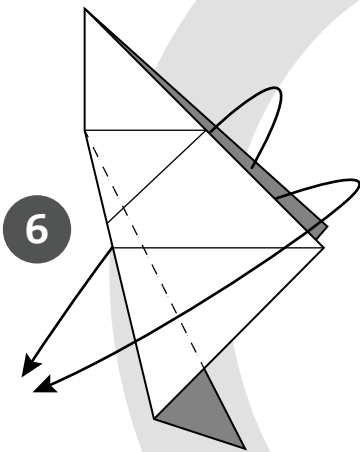
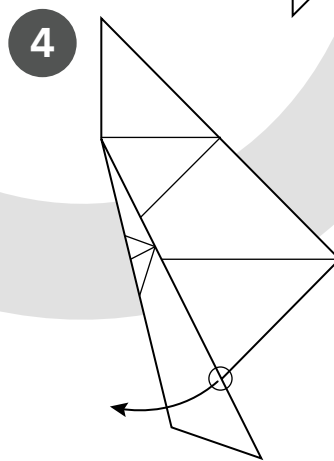
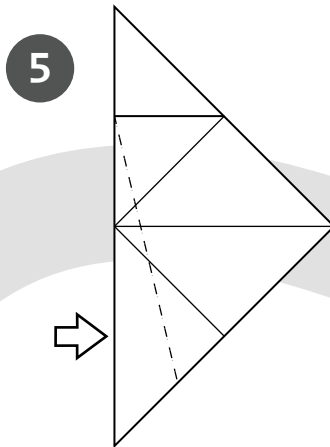
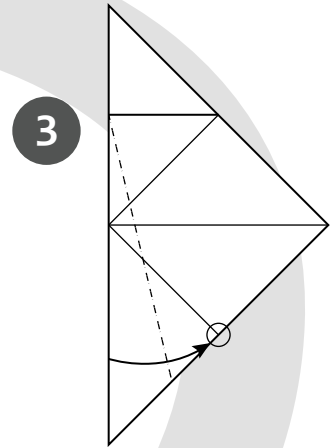
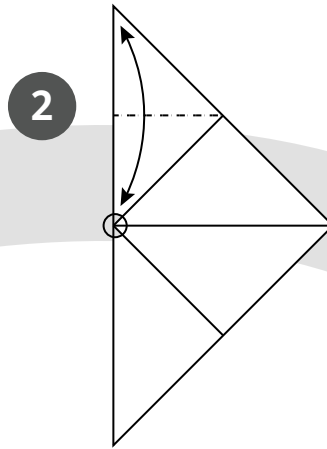
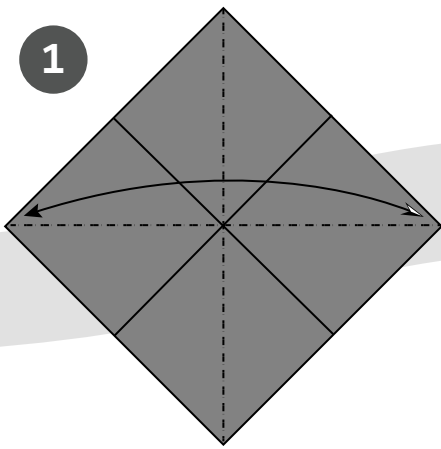
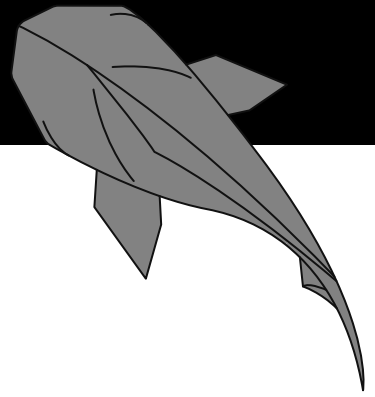

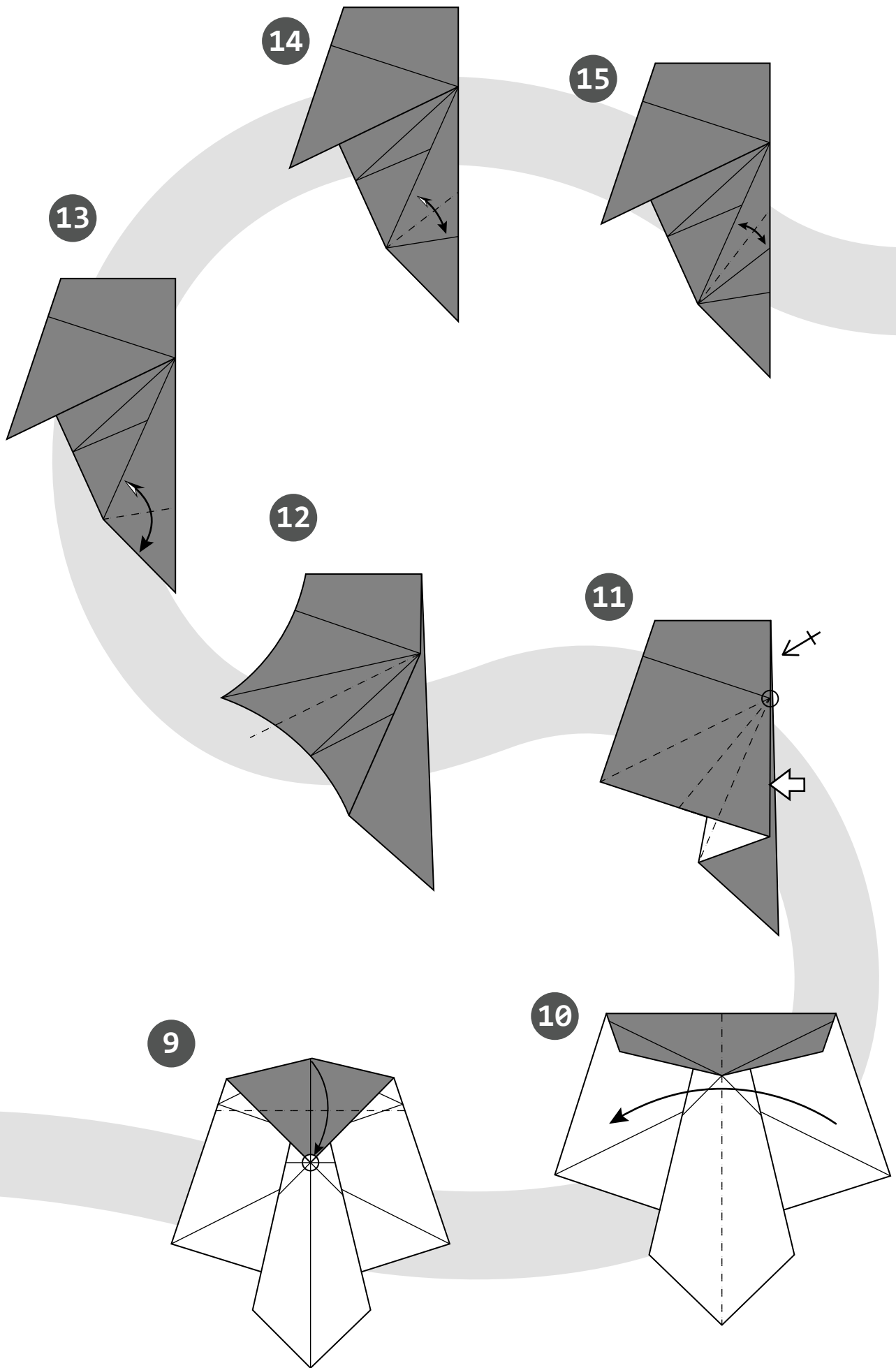

16

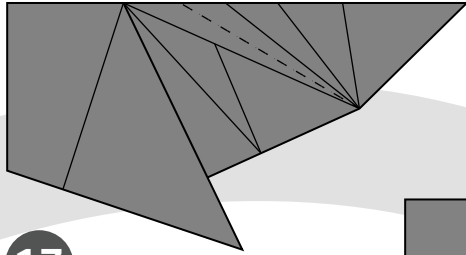
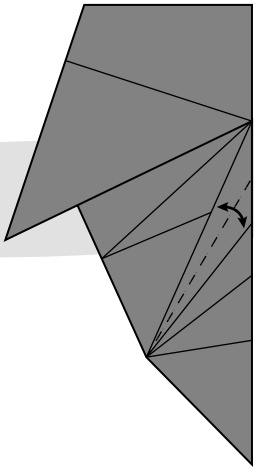

17

18

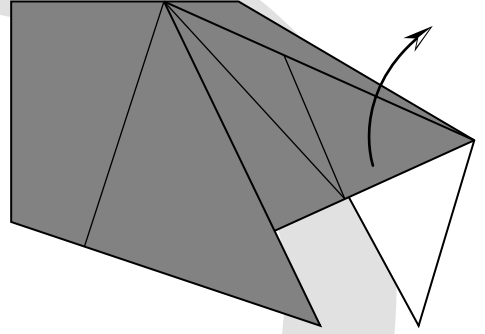

19

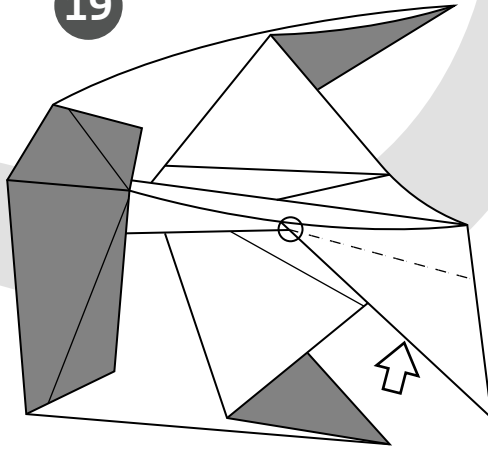

20

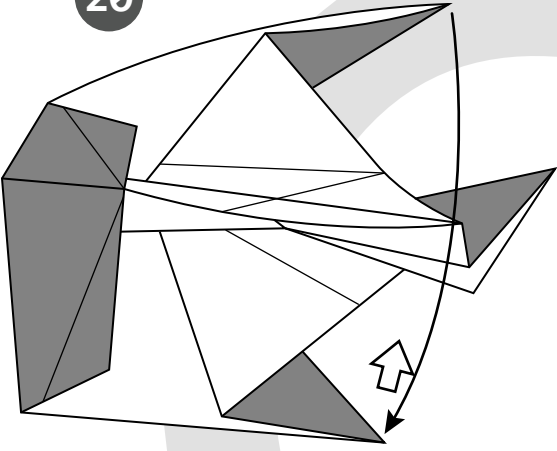

21

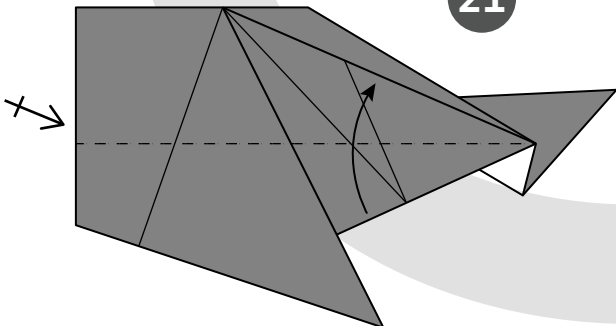

22

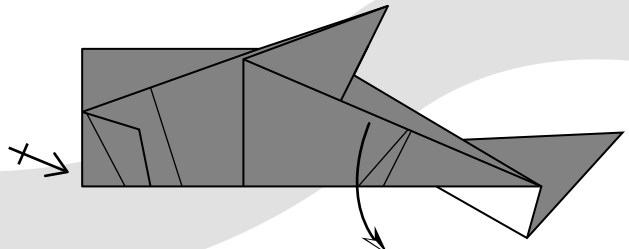

29

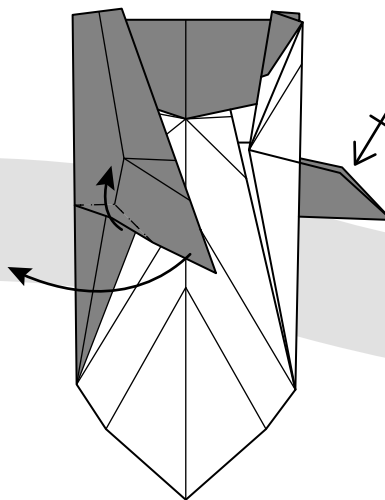

28

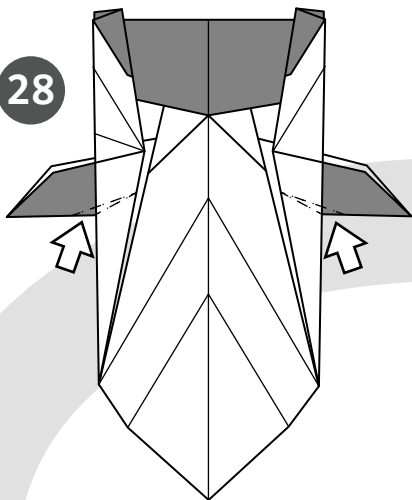

26

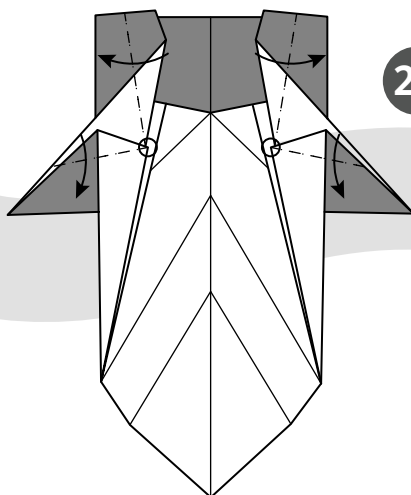

27

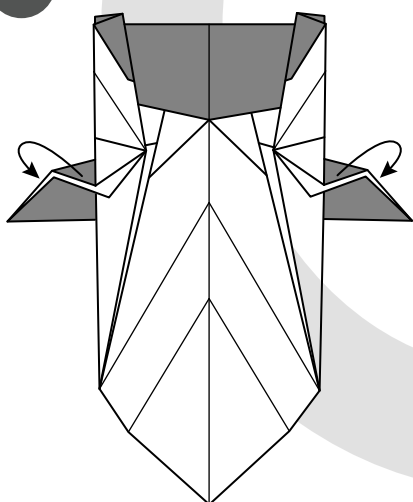

90°

25

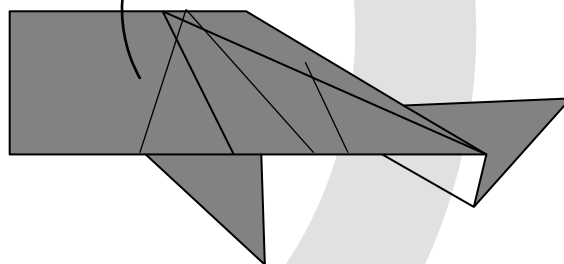

23

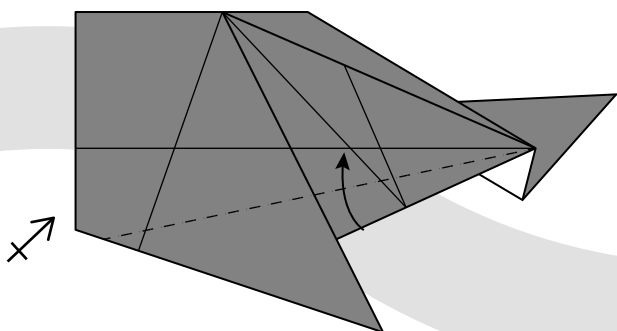

24

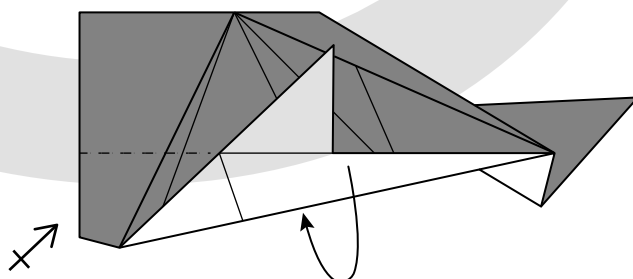



29

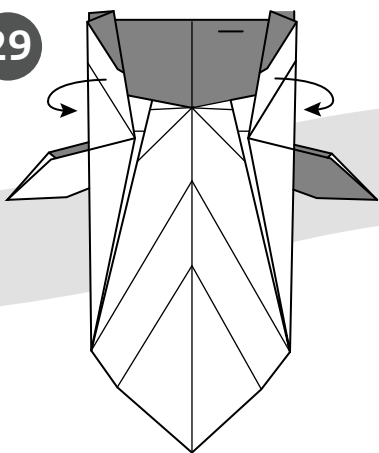

30

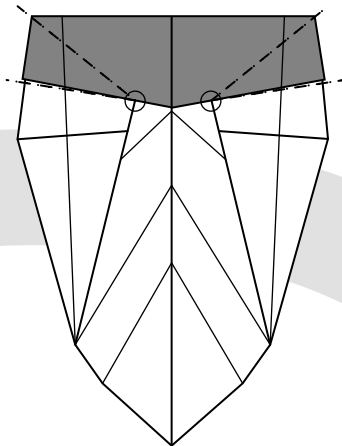

31

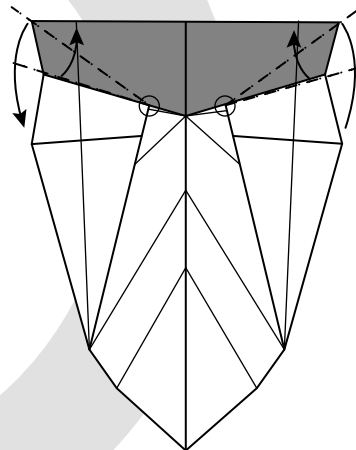

33

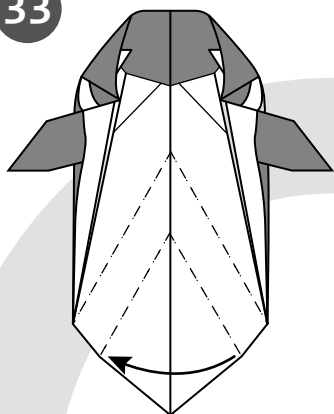

32

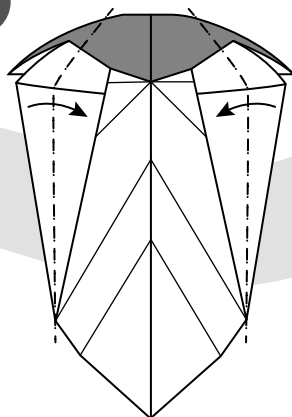

34

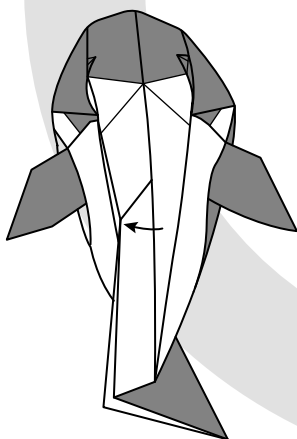

35

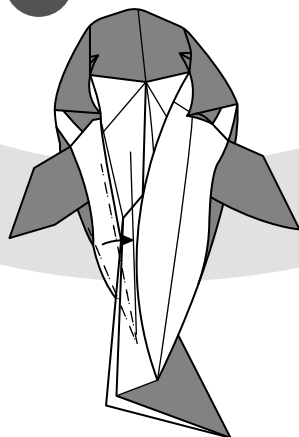

36

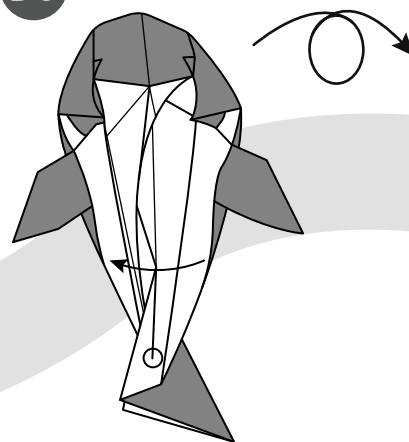

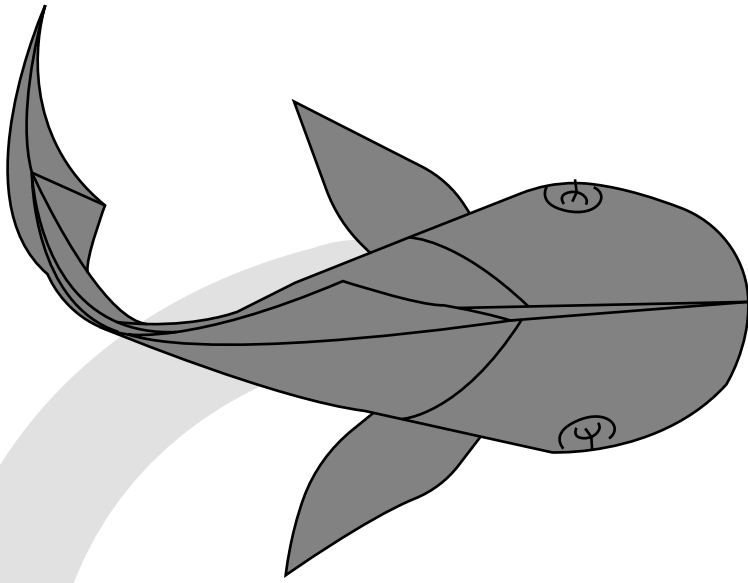

39

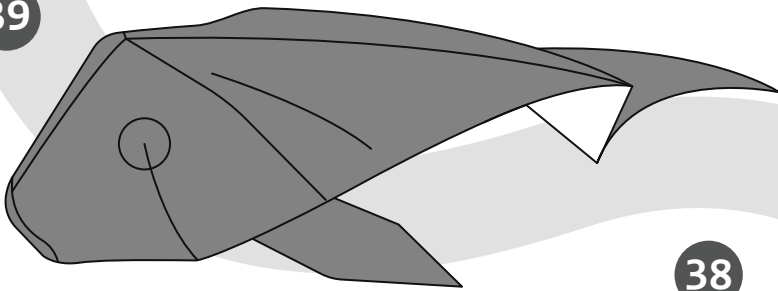

38

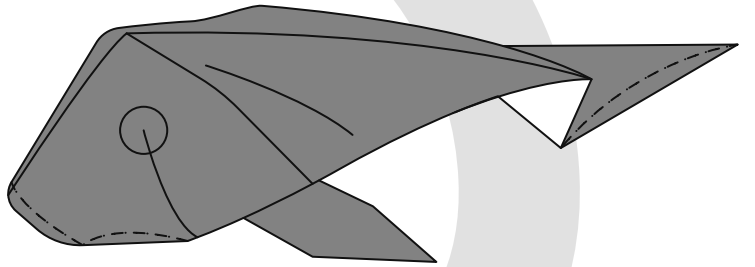

37

