

*FUN & EASY*

# Origami

## Premier pas

Découvrez les techniques pour réussir vos modèles origami +  
L'histoire de l'origami et des astuces unique

15+  
Modèles

*Gilles Adrien Petit*

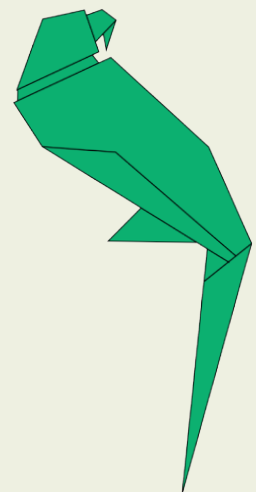
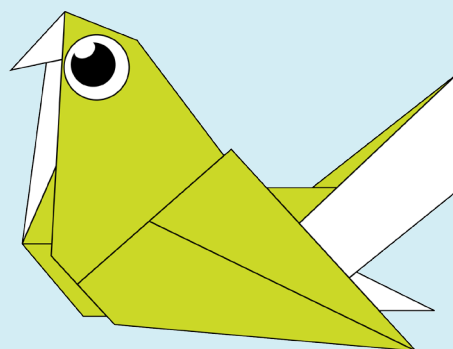
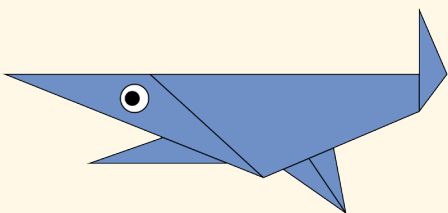

# Présentation de l'Origami (L'Histoire)

Le terme « Origami » Il a été élaboré en 1880. Auparavant le pliage de papier était appelé « Orikata ». Origami vient du Japonais, et est formé de l'association de 2 termes : Oru おる (Plier) et Kami かみ (Papier). L'Origami est du pliage de papier.

## Naissance de l'Origami

Né en Chine au Ier/IIème siècle environ, peu après l'invention du papier. Importé au Japon en même temps que le papier par les moines bouddhistes au VIème siècle. Les Maures apportent l'Origami en Europe (Espagne) au XIIIème siècle. Ils créaient principalement des formes géométriques, leur religion interdisant la reproduction de formes animales.

## Évolution de l'Origami

Au début, loisir réservé aux classes sociales élevées (papier rare et cher) Problème de la transmission exclusivement orale des techniques de pliages (l'illettrisme est récurrent à cette époque) Les Origami originaux sont secrètement gardés par les familles, signe de richesse L'Origami se développe lentement.

# Normalisation de l'Origami

**Akira Yoshizawa**, considéré comme « le père de l'Origami moderne » du fait de ses nombreuses créations originales, élabore en 1935 un ensemble de symboles et de normes pour la création de diagrammes d'Origami.



# COMPRENDRE LES SCHÉMAS ORIGAMI

## PRINCIPE GÉNÉRAL, RÈGLES DE BASES

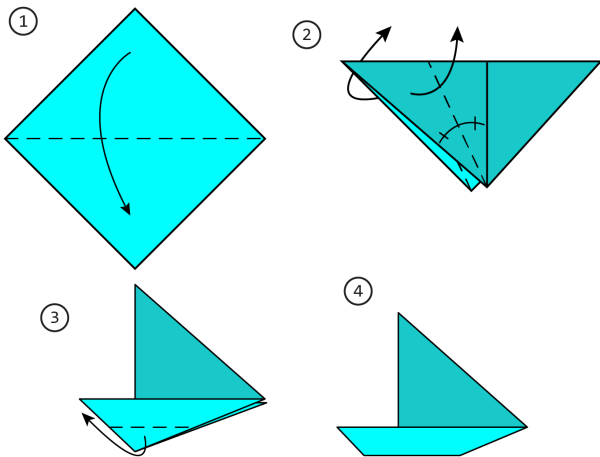

### Exemple du diagramme du bateau (très simple)

Les diagrammes : Est à l'origamiste ce que la partition est au musicien.

Permet d'obtenir un modèle grâce à la description précise d'une succession de plis. Les normes utilisées donnent une dimension universelle aux diagrammes. On s'affranchit de la barrière de la langue par l'utilisation de symboles divers mais précis.

### Les symboles Les plis de bases

Permettent de codifier les actions à réaliser

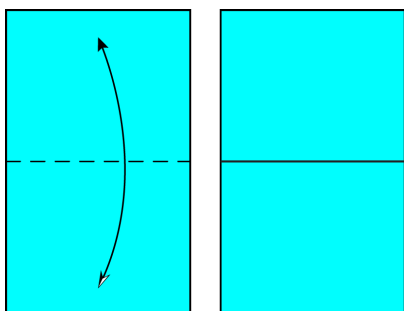

Plier et déplier

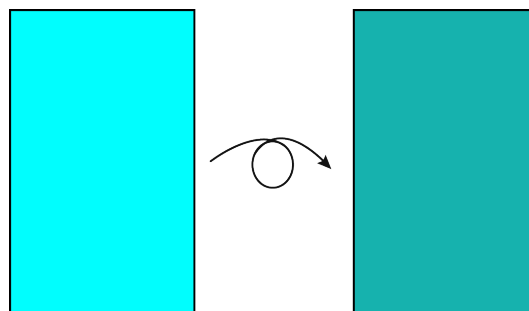

Retourner la feuille

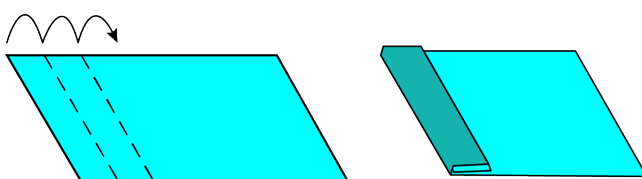

Plier et replier

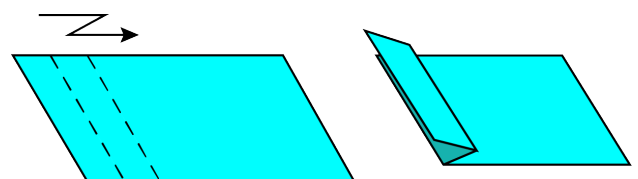

Plier en accordéon

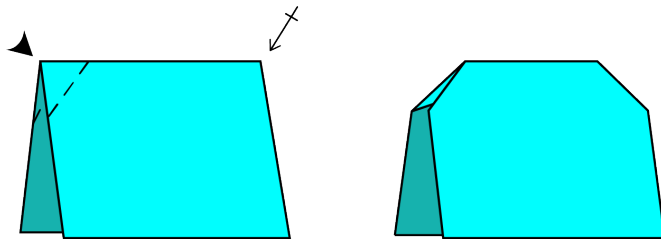

Répéter 1 fois l'action. Le nombre de répétitions à effectuer est définie par le nombre de petits traits perpendiculaires à la flèche.

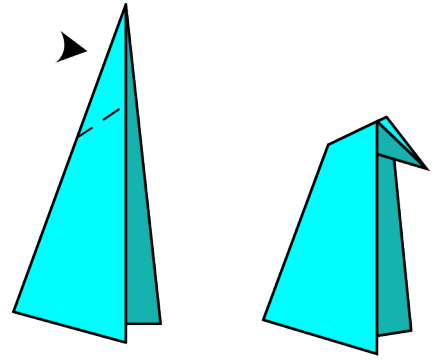

**Enfoncer**

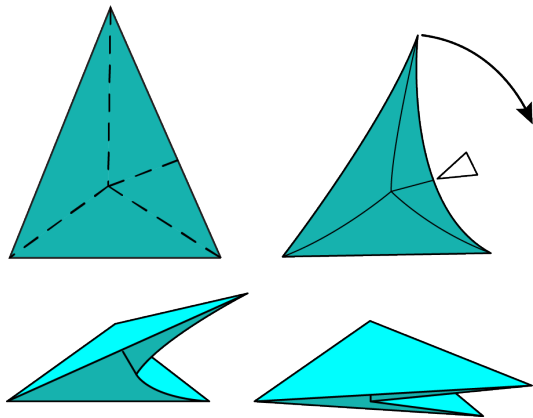

**Oreille de lapin**

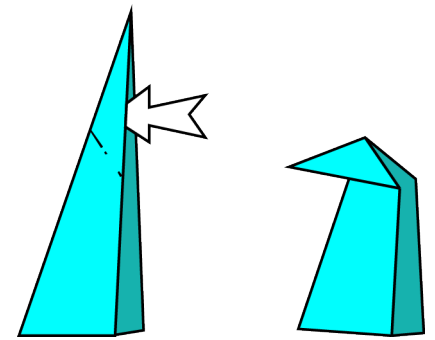

**Ouvrir le papier**

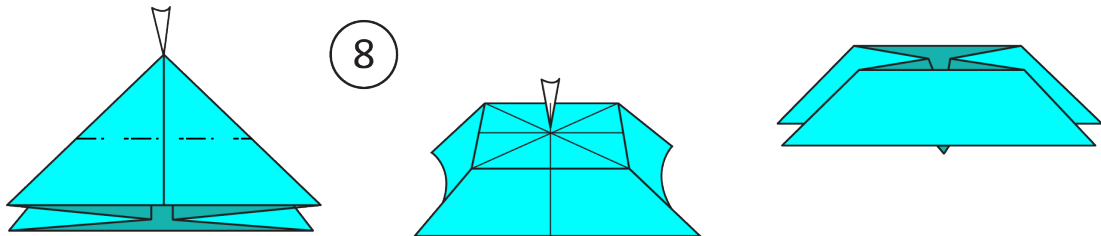

**Pli enfoncé (ouvert)**

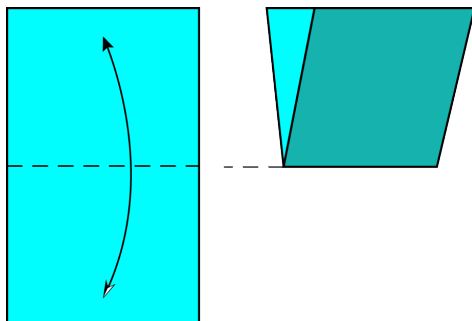

**Pli vallée (en forme de vallée)**

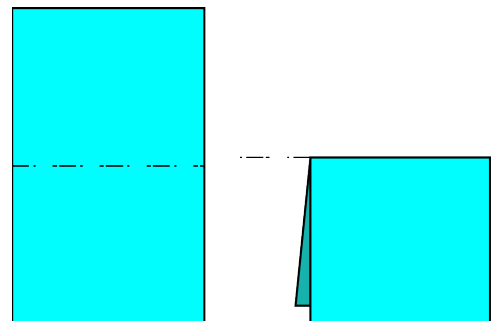

**Pli montagne (en forme de montagne)**

Il est important de ne pas confondre les 2 plis, leur forme peut avoir beaucoup d'importance et faciliter la suite de la réalisation !

# Les plis complexes

Ils interviennent dans des modèles de niveau supérieurs

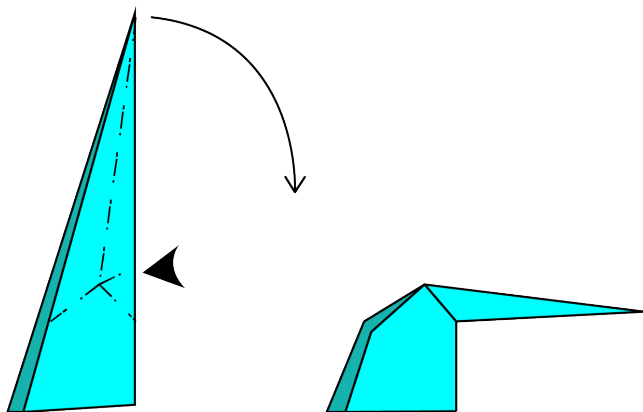

Double oreille de lapin

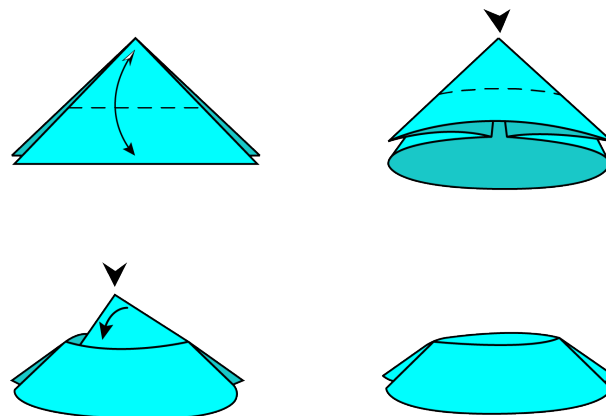

Pli enfoncé (fermé)

# Les bases

Regroupe un ensemble de plis communs à de nombreux modèles

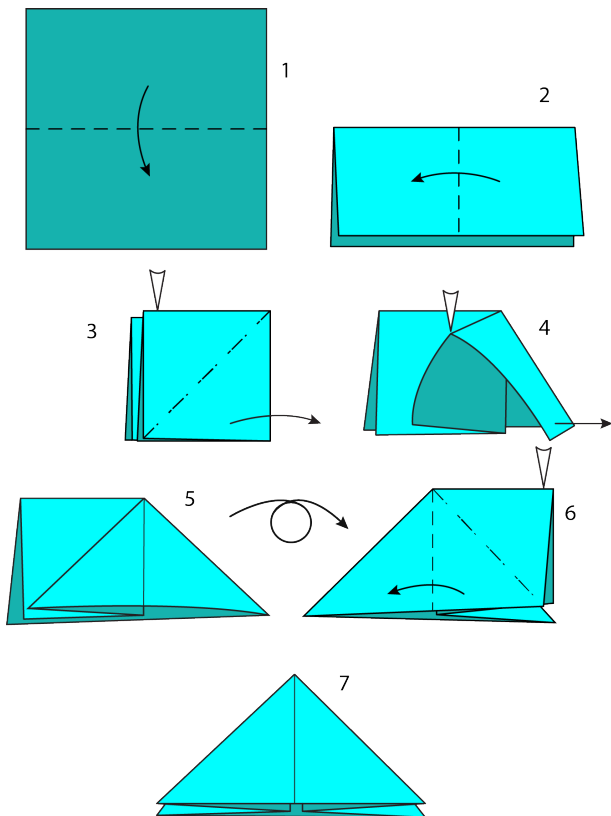

Base de la bombe à eau

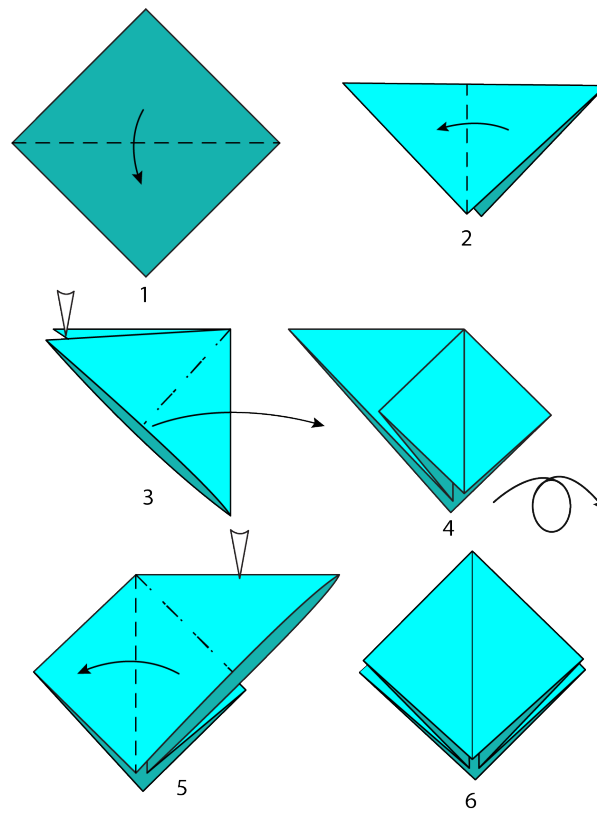

La base préliminaire

# Les plis complexes

Ils interviennent dans des modèles de niveau supérieurs

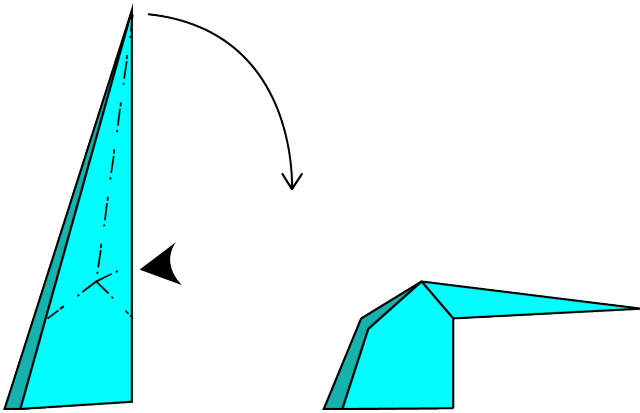

Double oreille de lapin

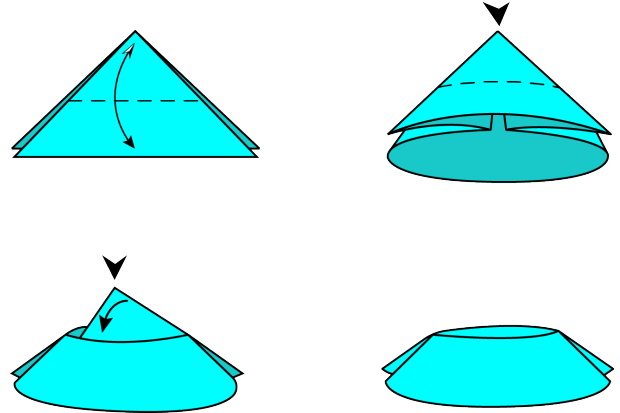

Pli enfoncé (fermé)

# Les bases

Regroupe un ensemble de plis communs à de nombreux modèles

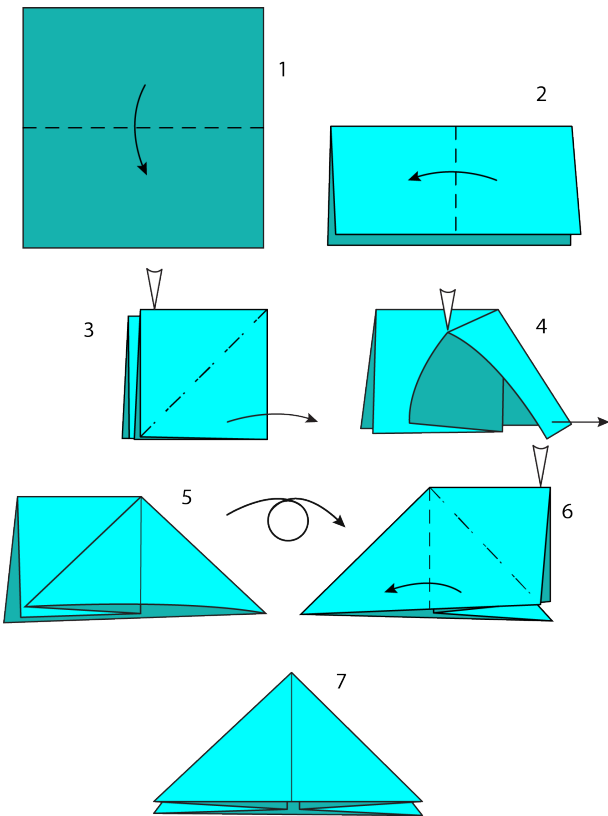

Base de la bombe à eau

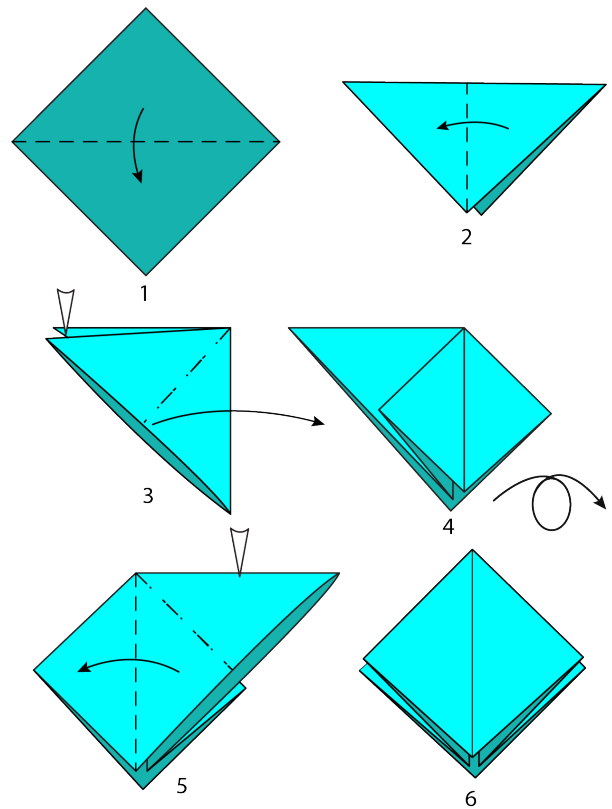

La base préliminaire

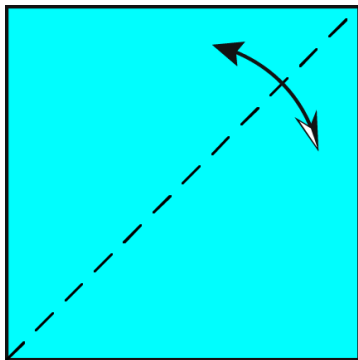

1

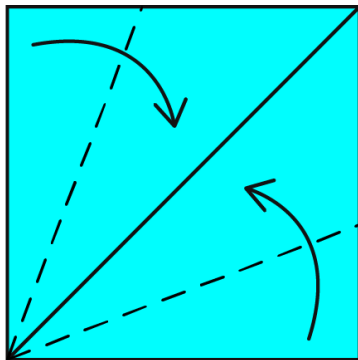

2

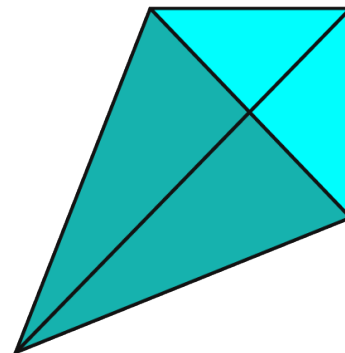

3

## La base du cerf-volant

Réalisation d'un diagramme par la classe... Vous allez pouvoir mettre en application vos fraîches connaissances d'Origamistes !

## Les papiers recommandés pour bien débuter l'origami



*Lien direct :*

➔ <https://amzn.to/2WpJEp7>

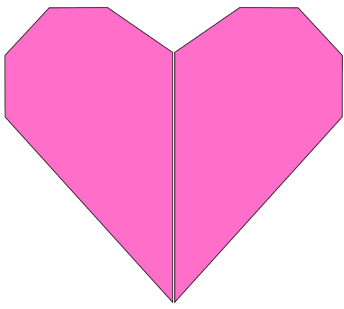

**Coeur**  
Page . 10

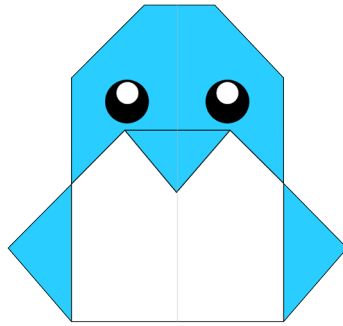

**Pingouin**  
Page .11

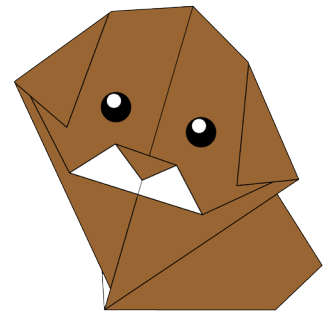

**Chien**  
Page . 12

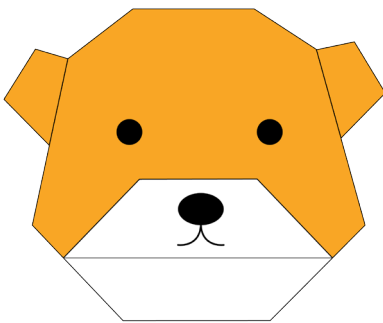

**Tête d'ours**  
Page .13

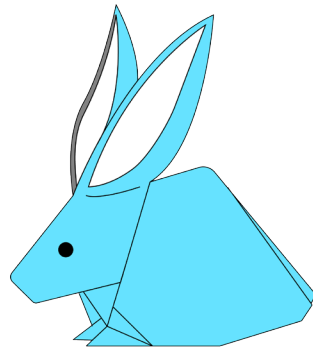

**Lapin**  
Page .14

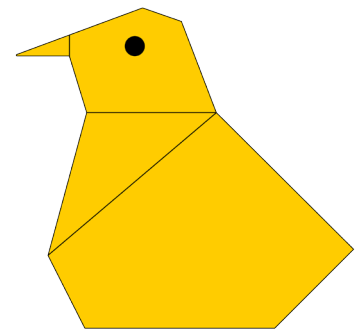

**Poussin**  
Page . 15

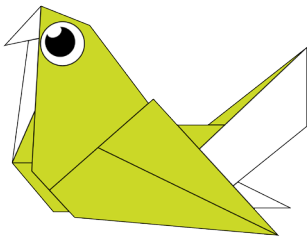

**Pigeon**  
Page . 16

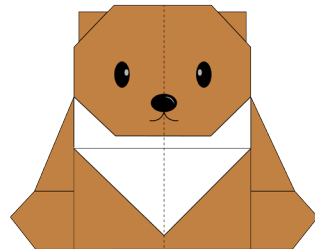

**Ours**  
Page . 17

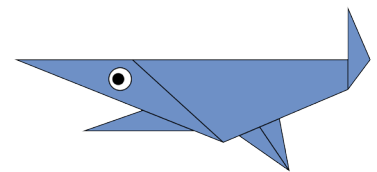

**Requin**  
Page . 18

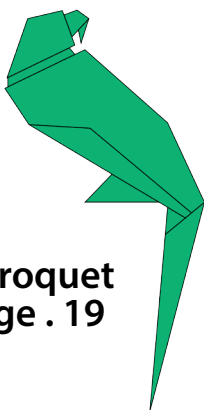

**Perroquet**  
Page . 19

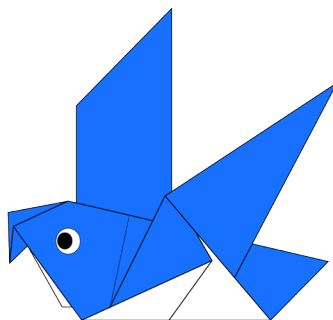

**Oiseaux**  
Page . 20

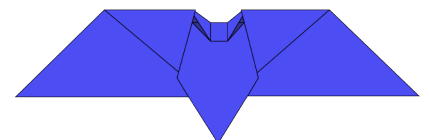

**Chauve souris**  
Page . 21

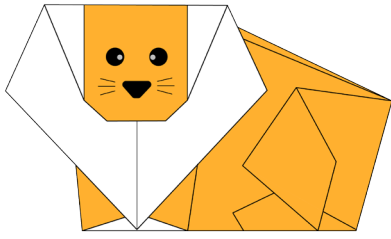

**Pigeon**  
Page . 22

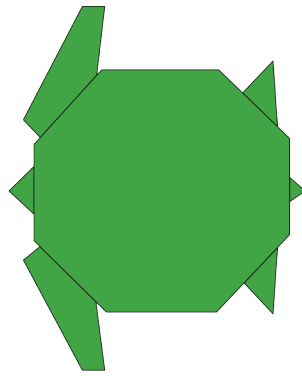

**Tortue**  
Page . 23

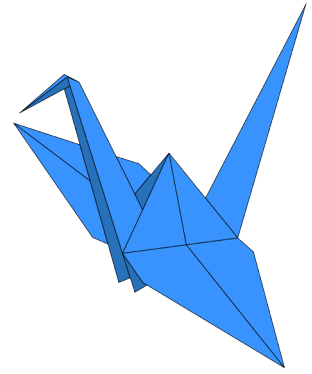

**Requin**  
Page . 24

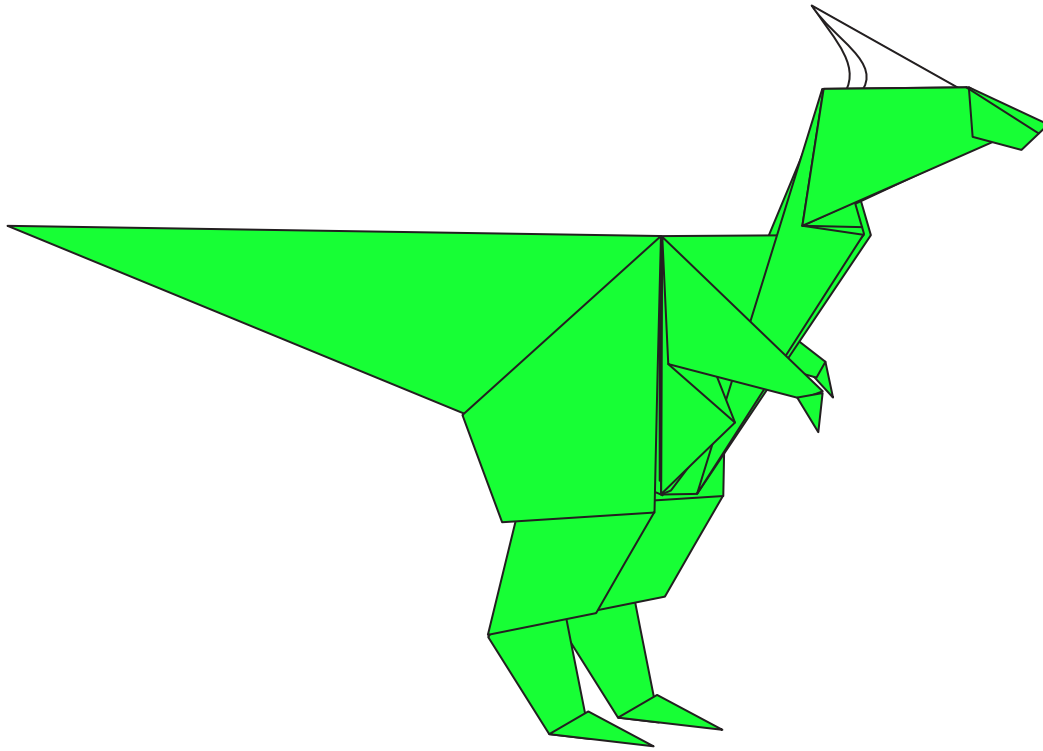

**BONUS**  
**Bébé Dinausore**  
Page. 25

COEUR: ★☆☆☆☆

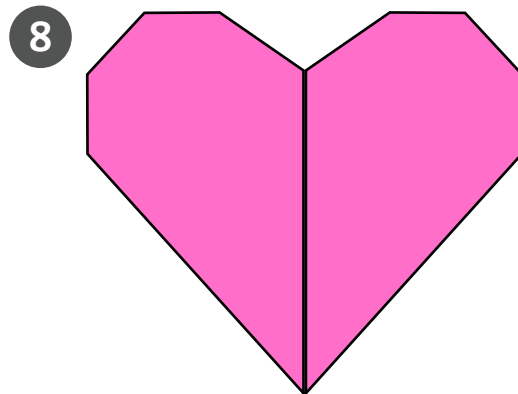
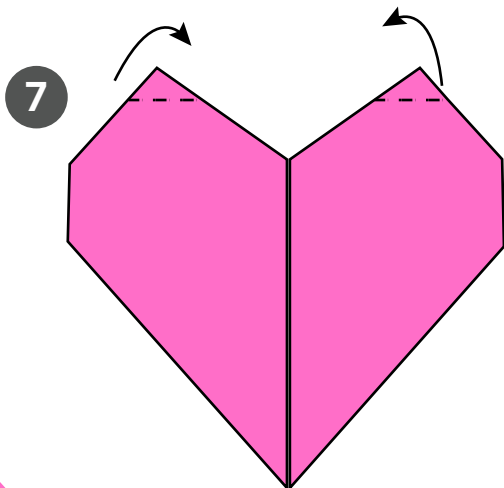
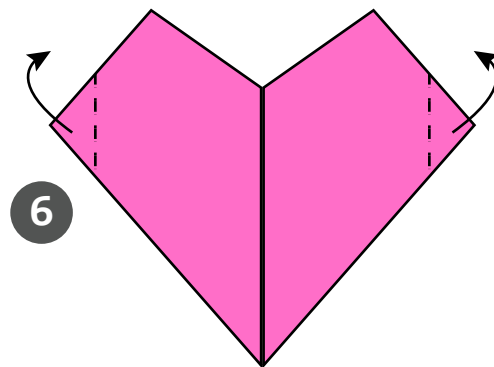
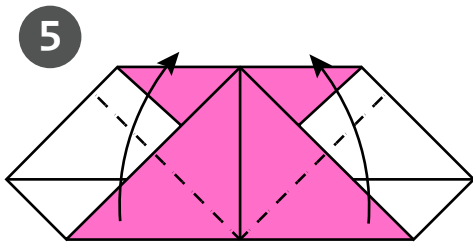
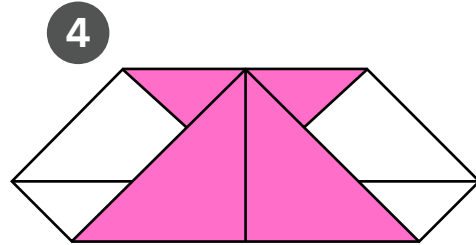
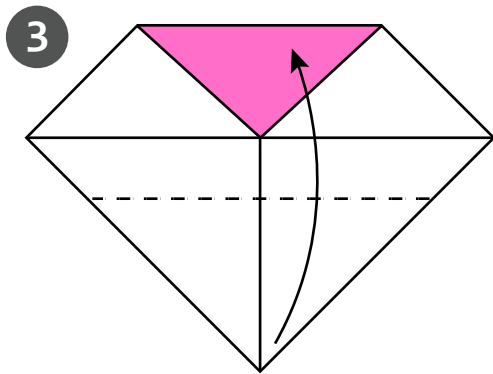
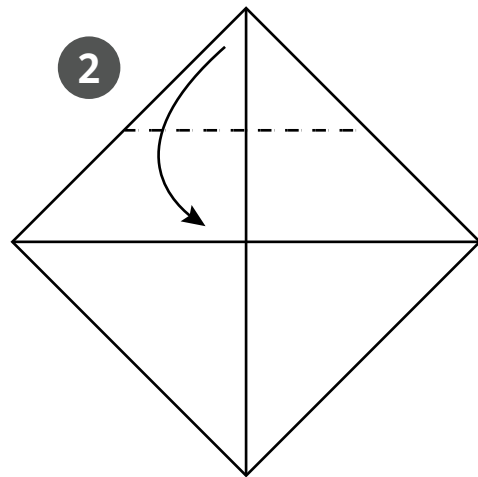
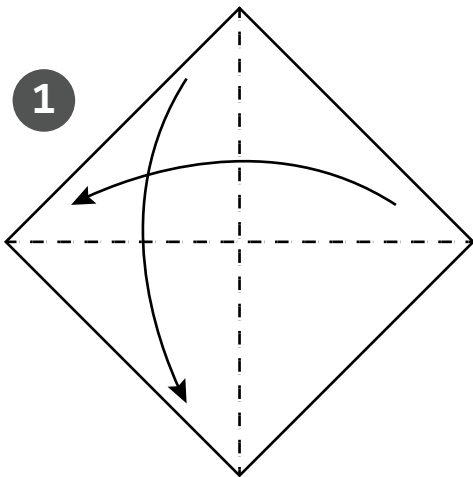

**PINGOUIN:** ★☆☆☆☆

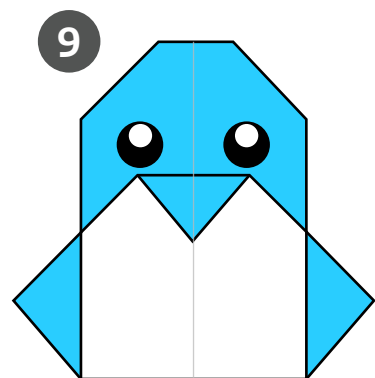
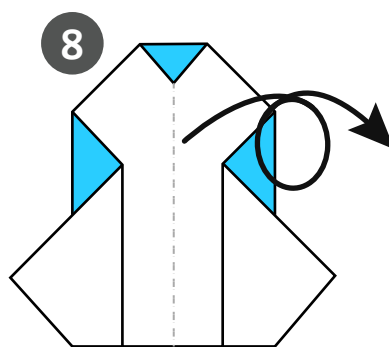
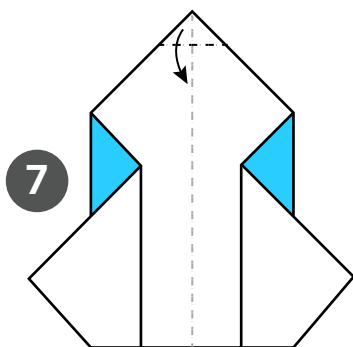
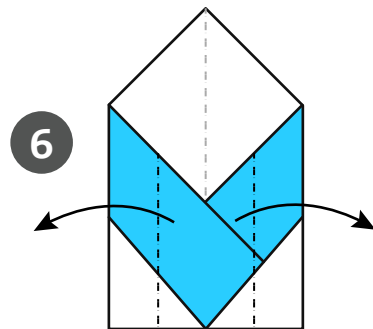
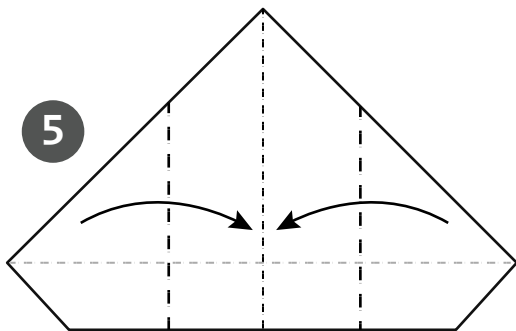
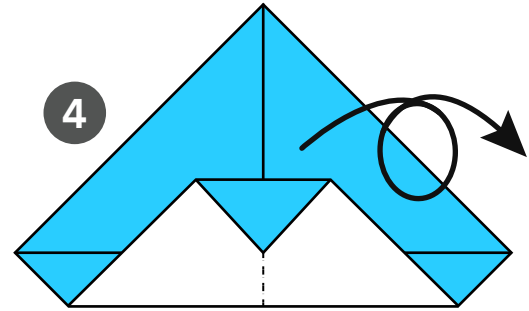
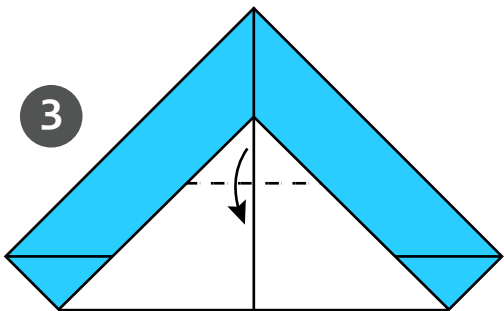
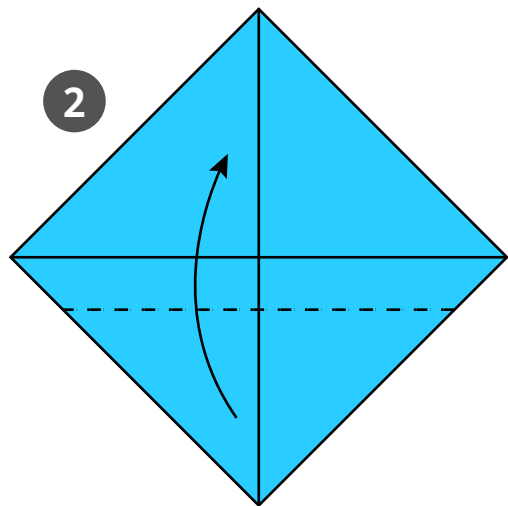
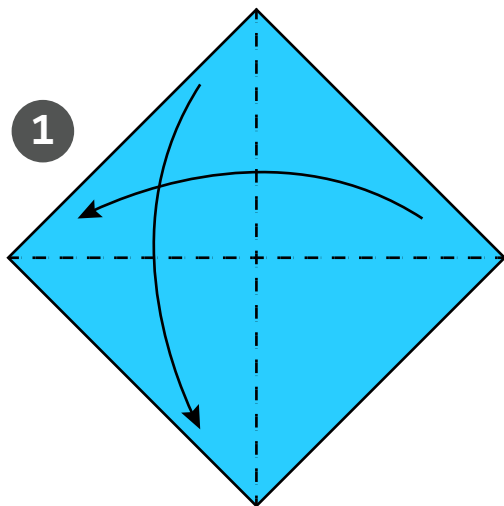

**CHIEN:** ★☆☆☆

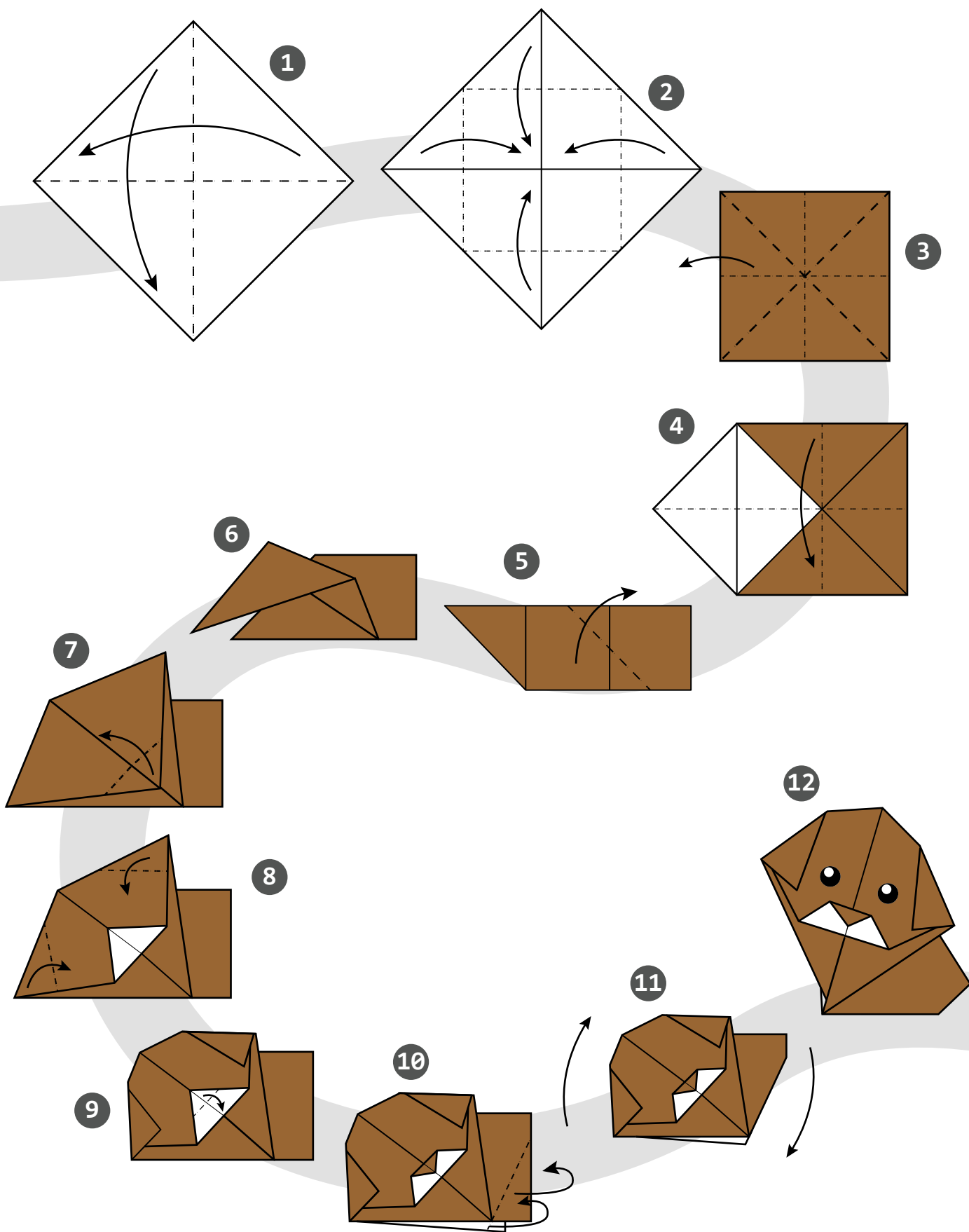

OURS: ★☆☆☆

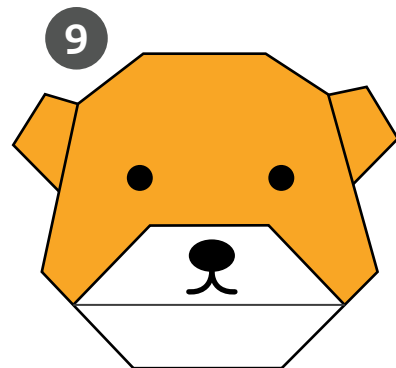
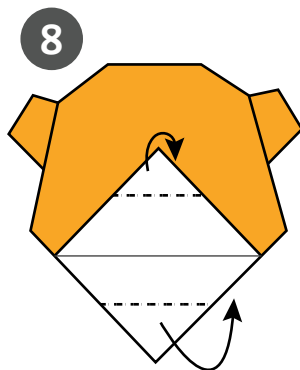
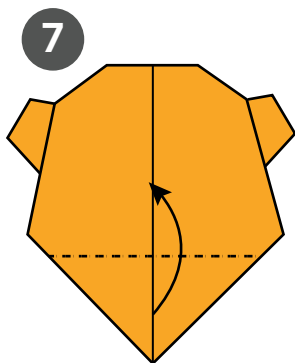
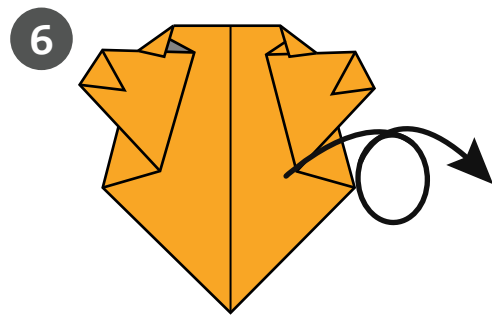
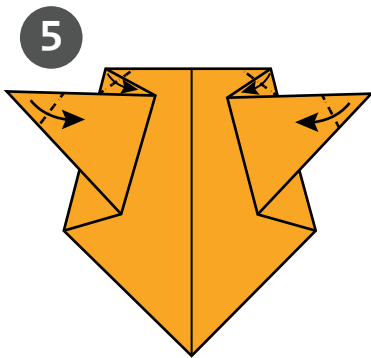
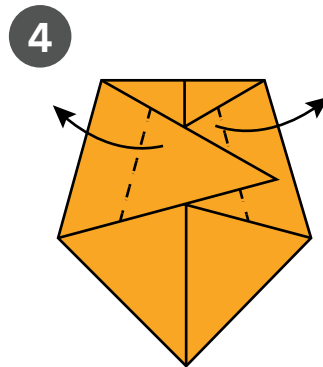
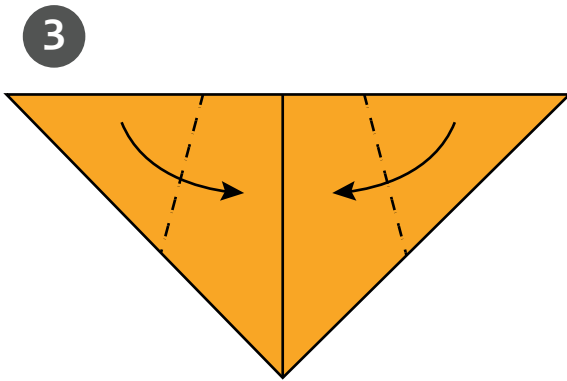
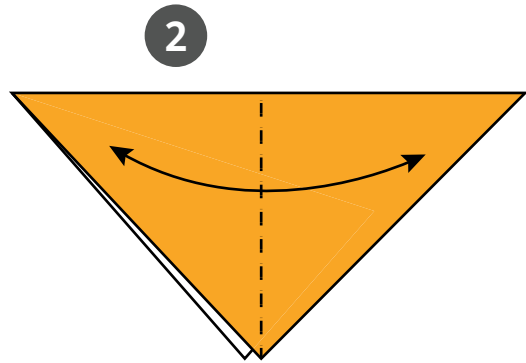
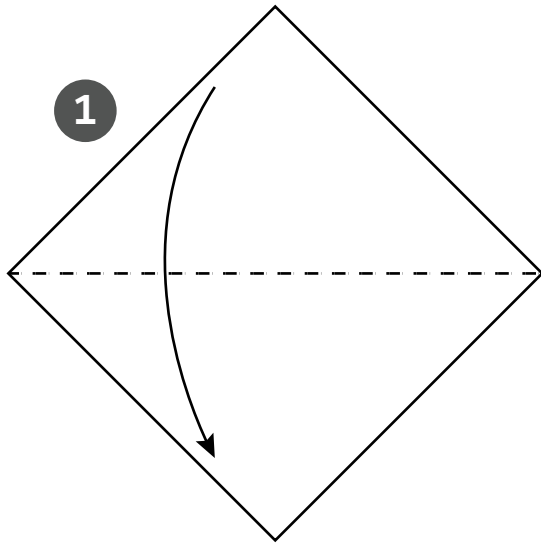

# LAPIN : ★☆☆☆☆

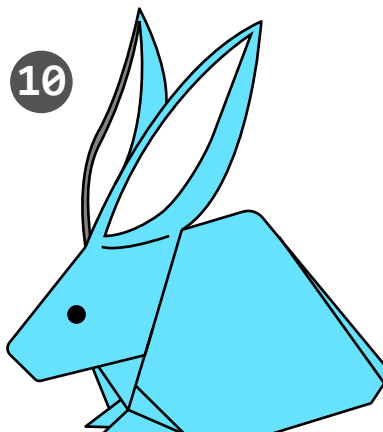
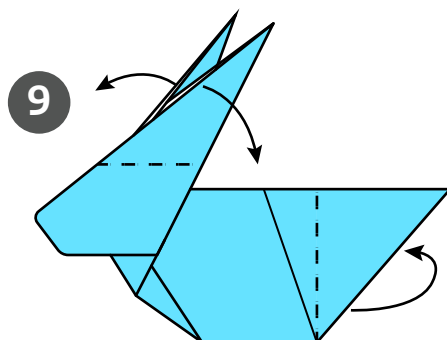
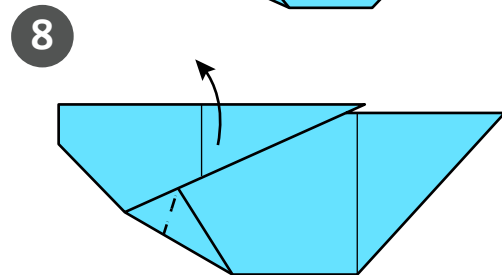
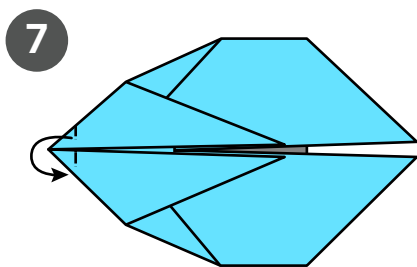
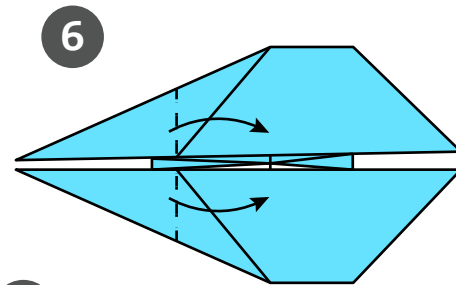
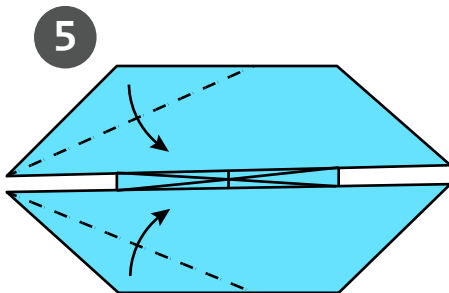
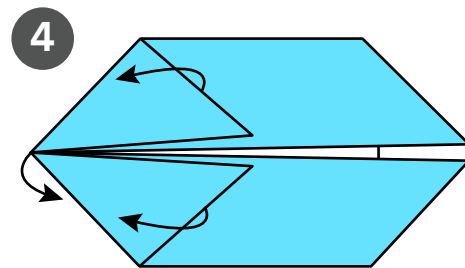
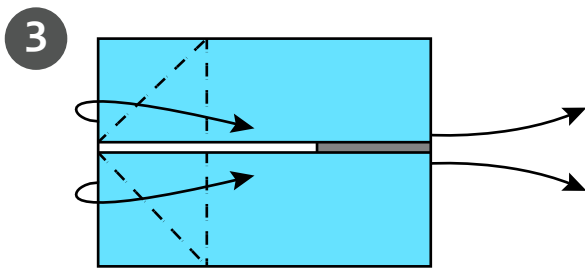
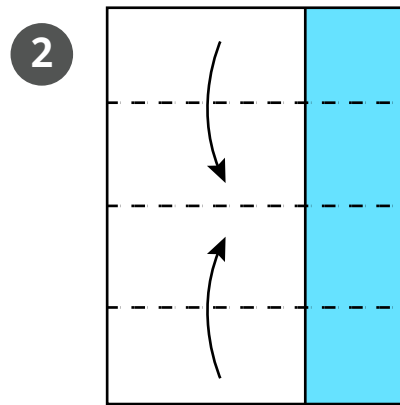
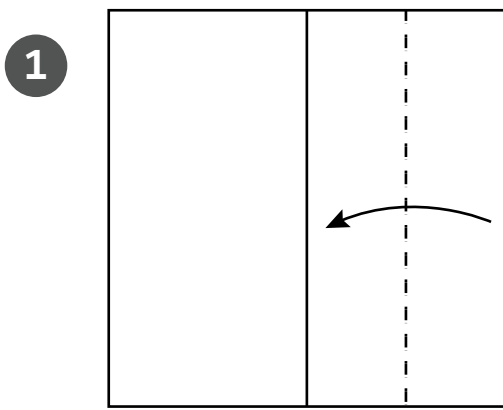

**POUSSIN :** ★☆☆☆

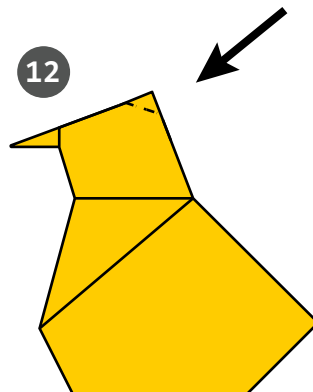
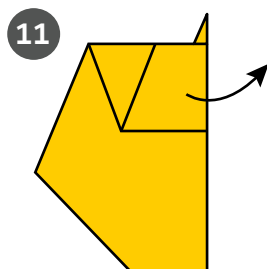
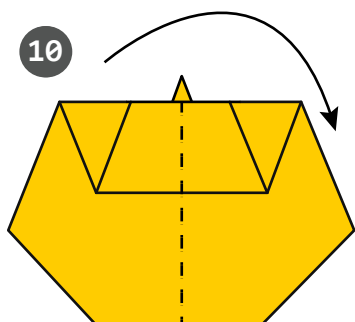
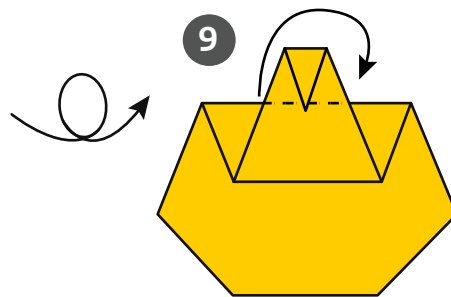
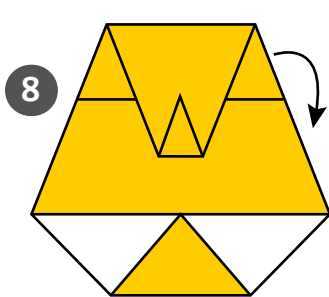
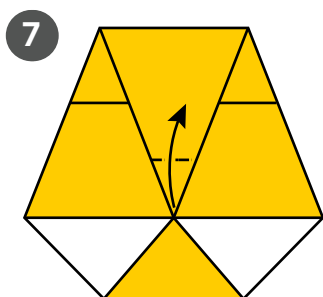
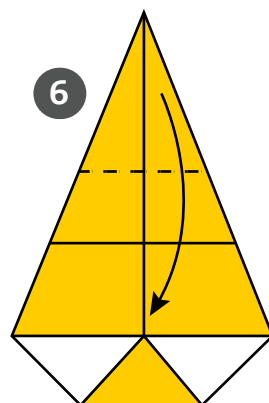
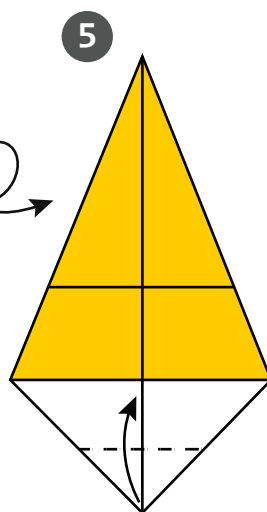
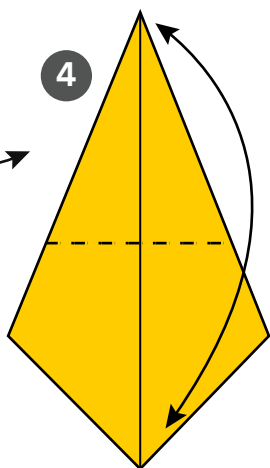
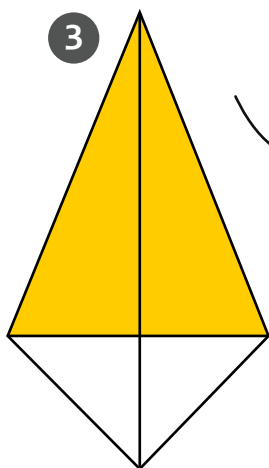
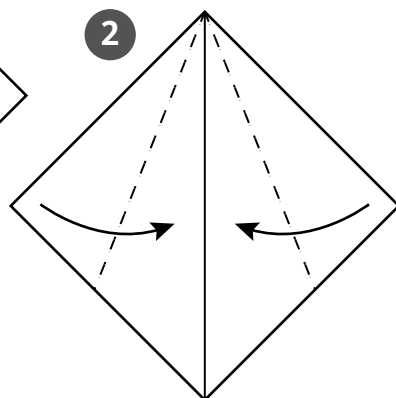
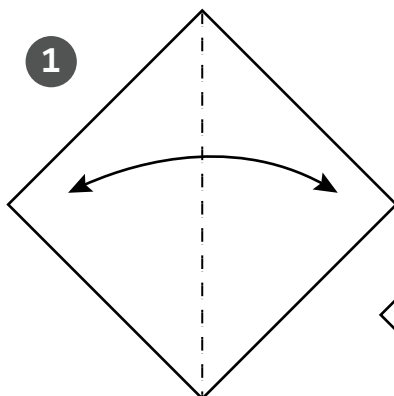
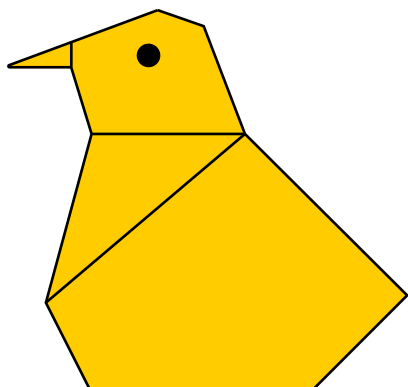

**PIGEON:** ★★☆☆

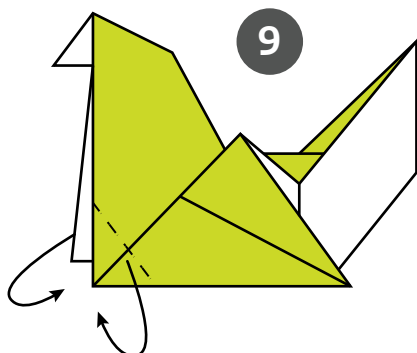
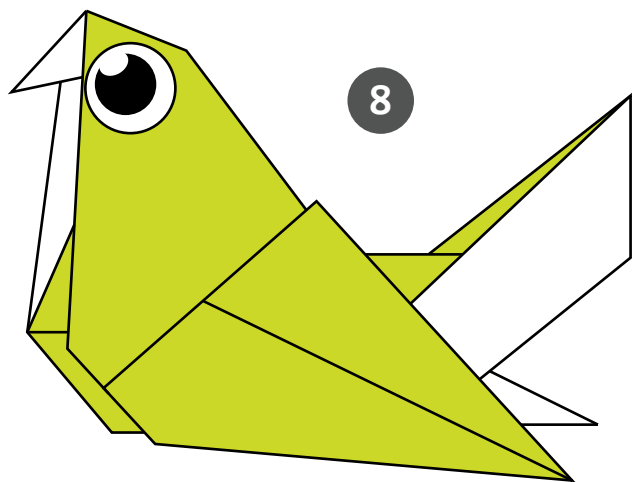
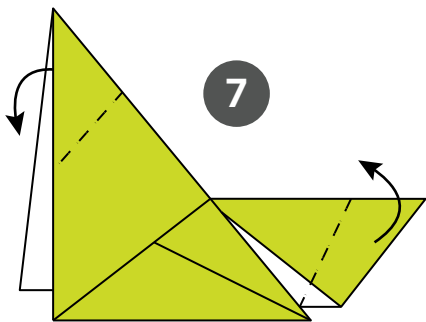
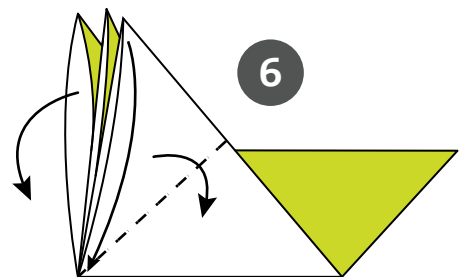
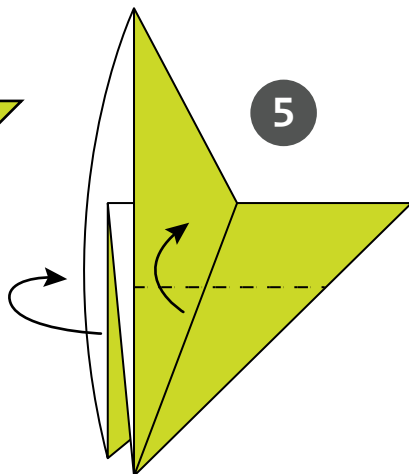
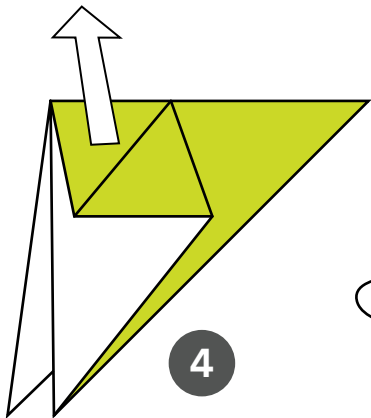
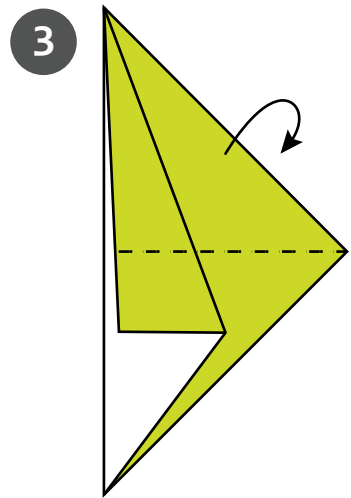
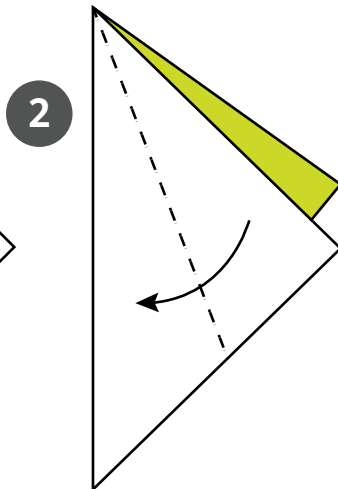
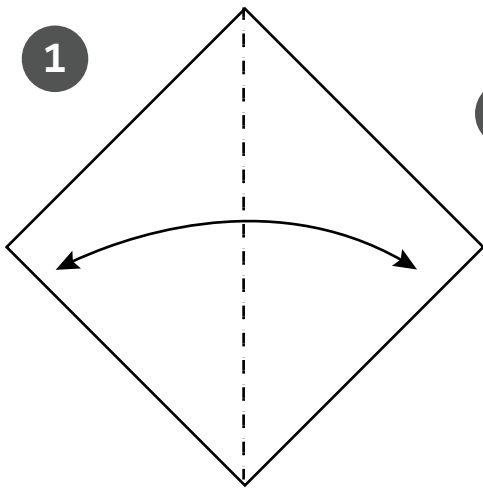

OURSON : ★☆☆☆

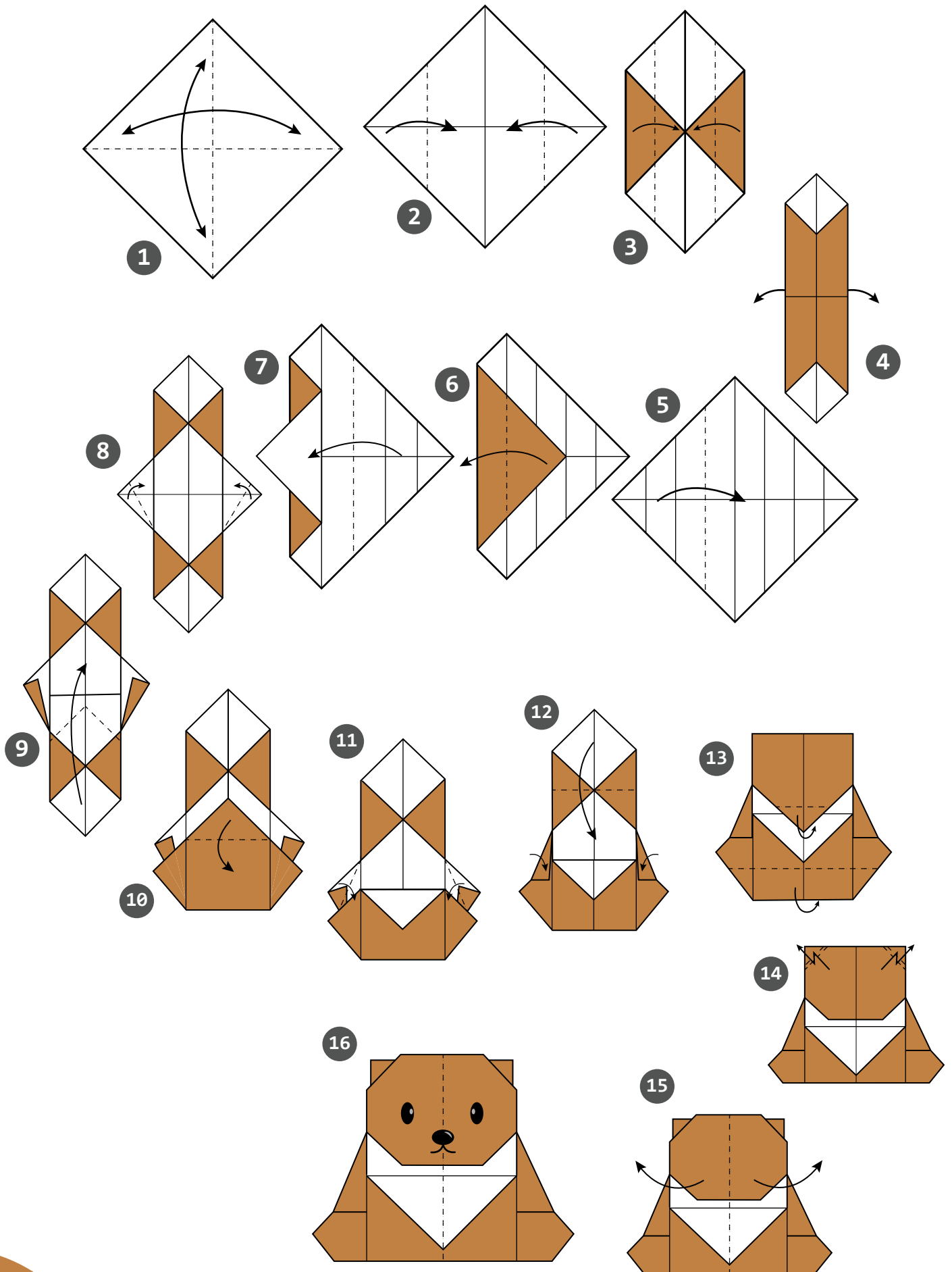

REQUIN: ★☆☆☆

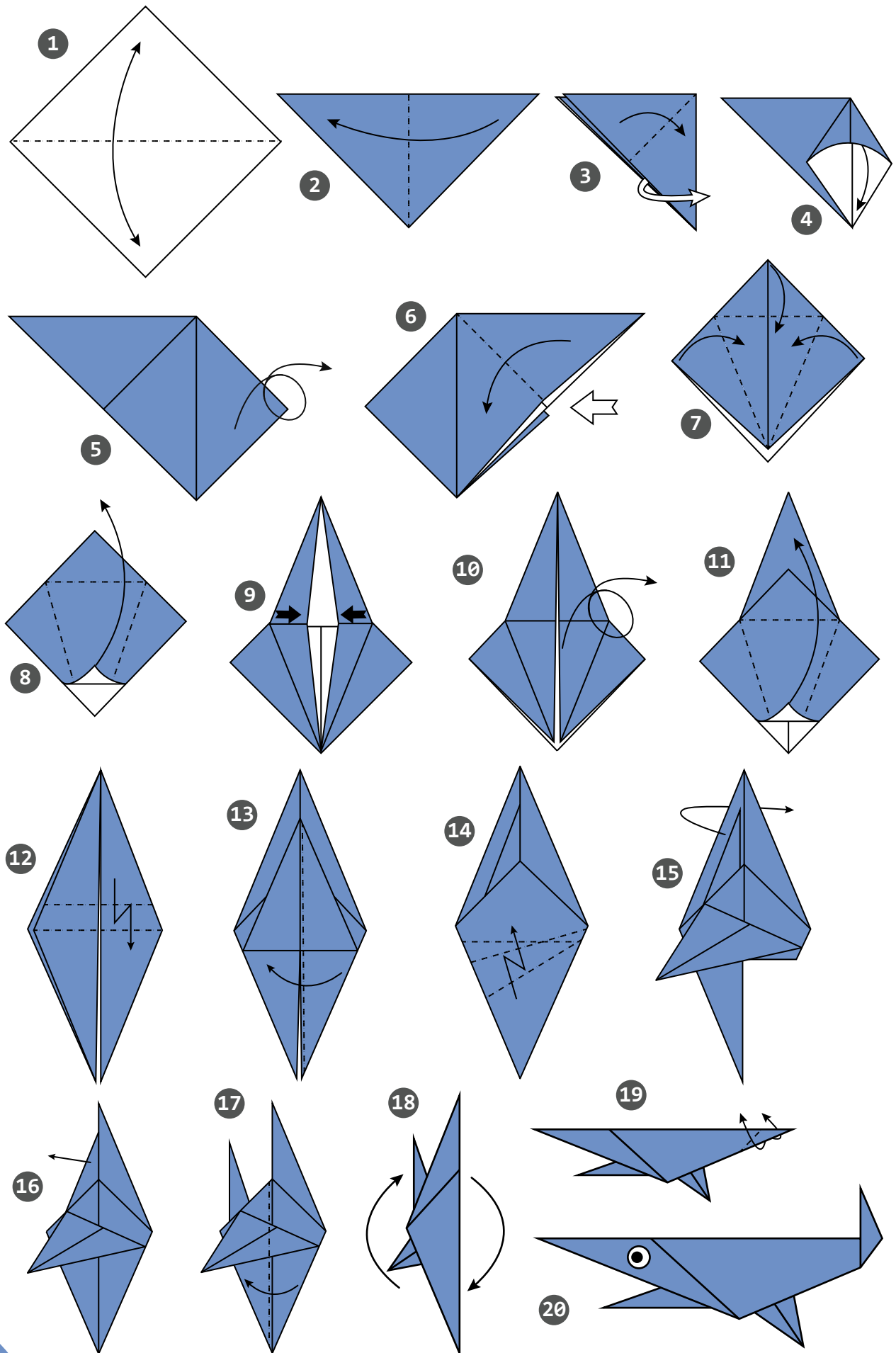

**PERROQUET:** ★★☆☆

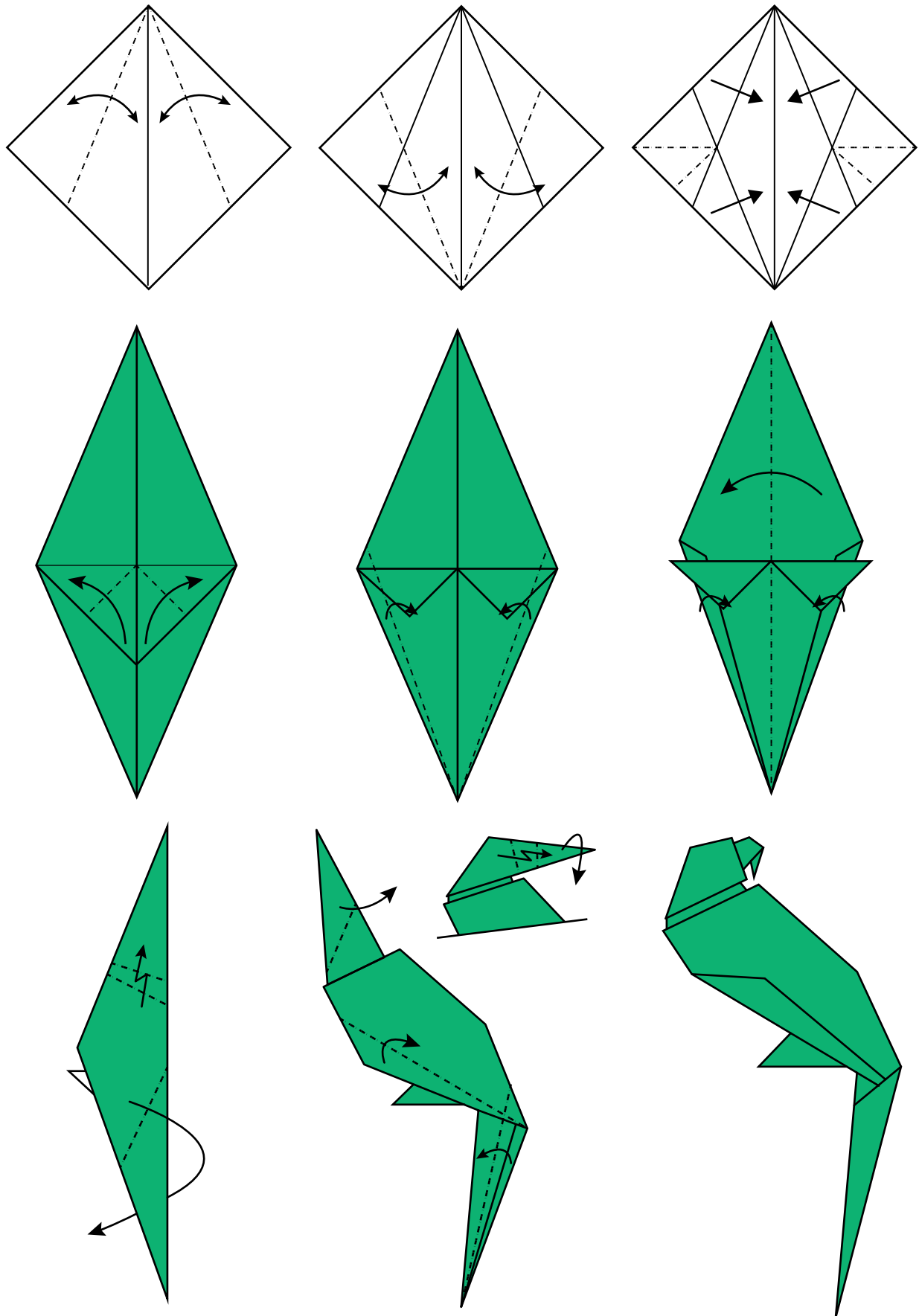

OISEAUX : ★☆☆☆

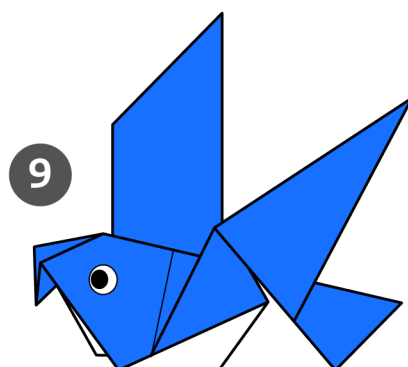
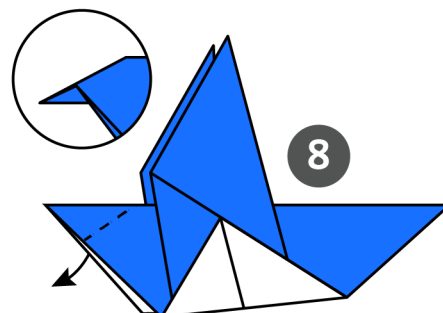
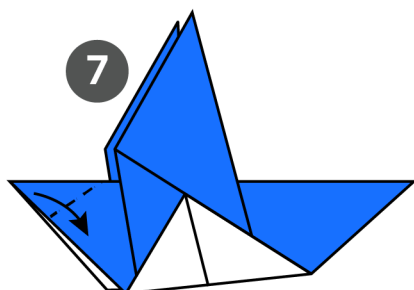
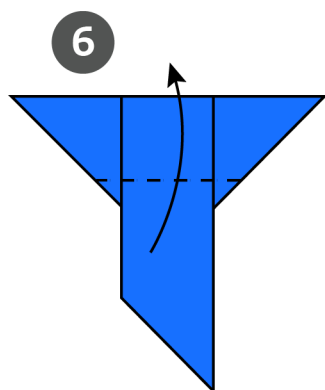
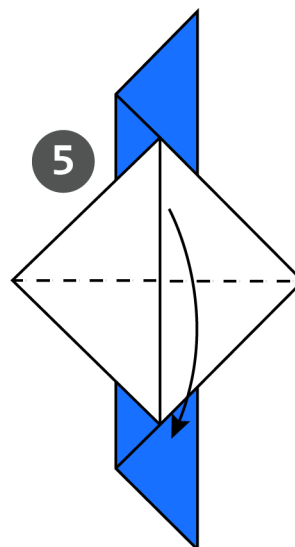
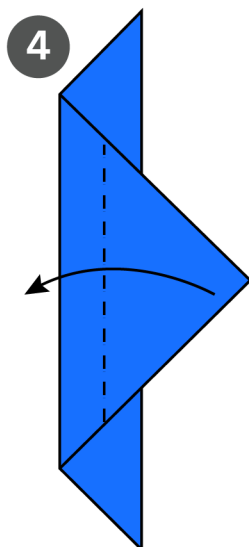
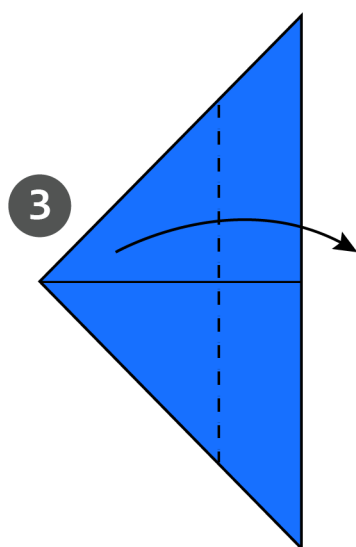
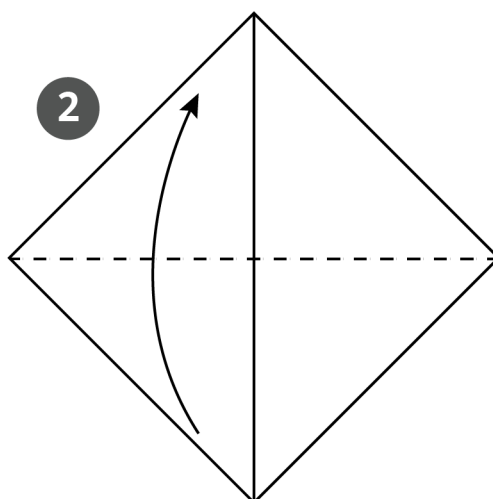
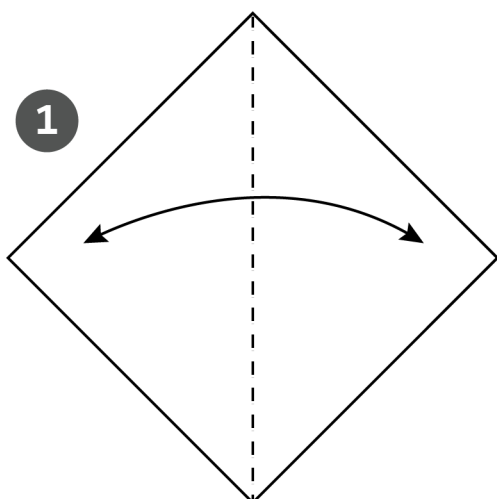

# CHAUVE SOURIS : ★★☆☆☆

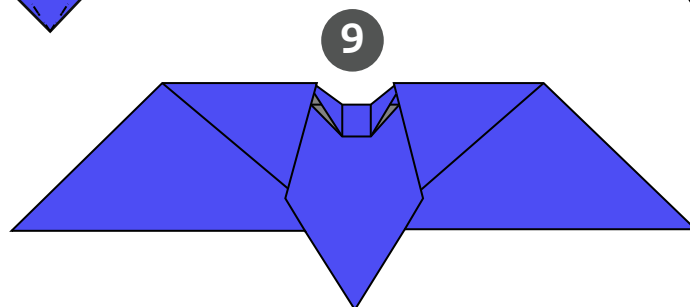
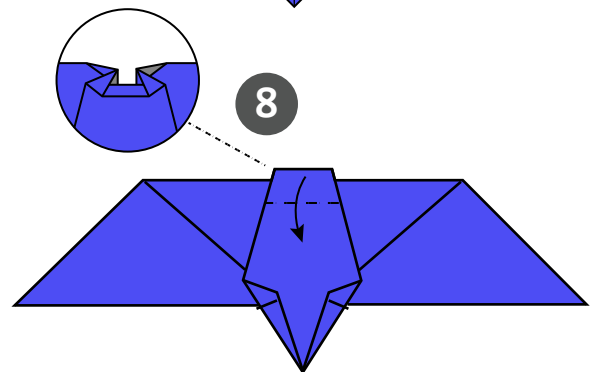
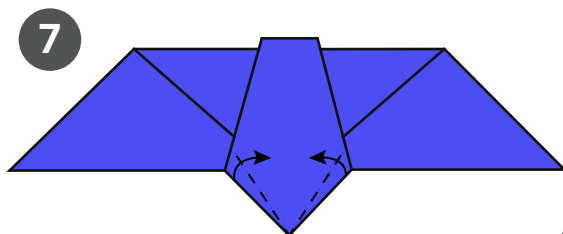
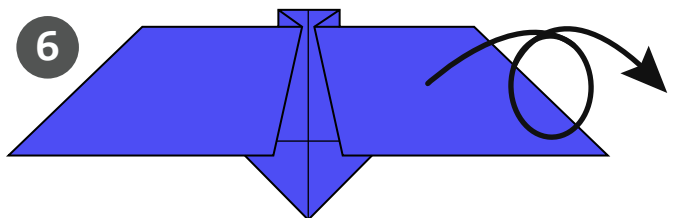
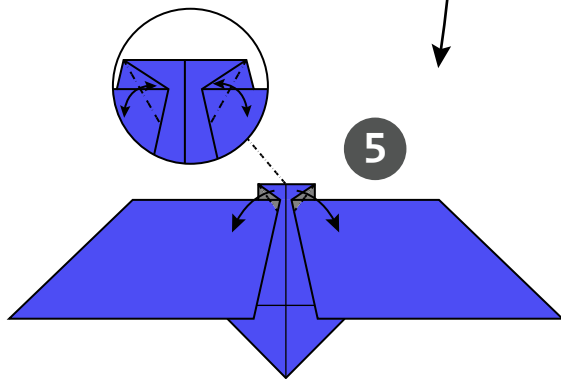
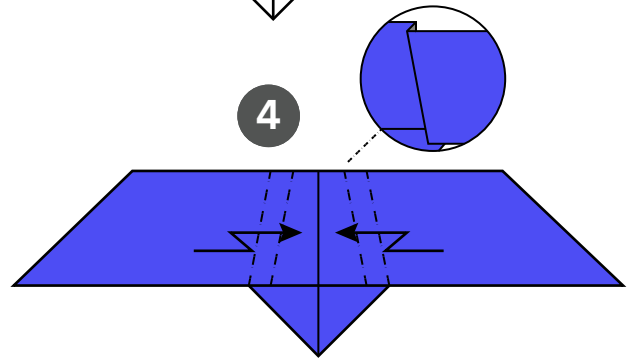
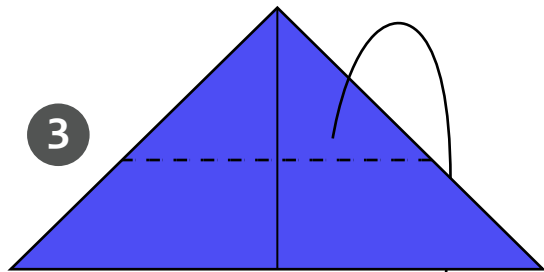
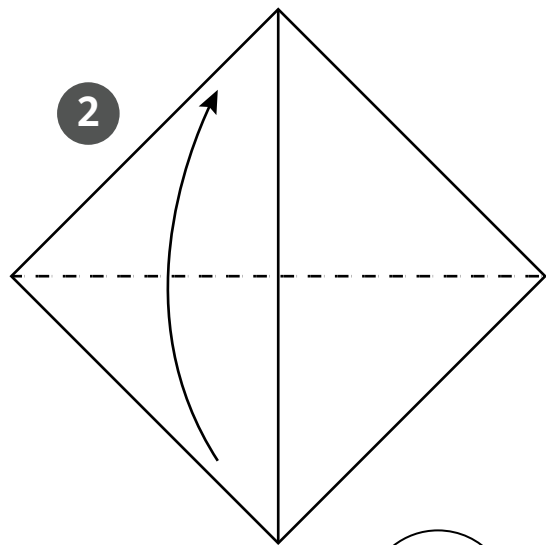
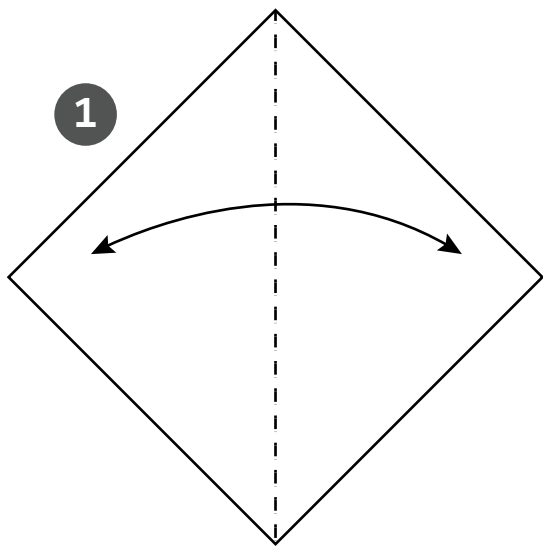

LION: ★☆☆☆

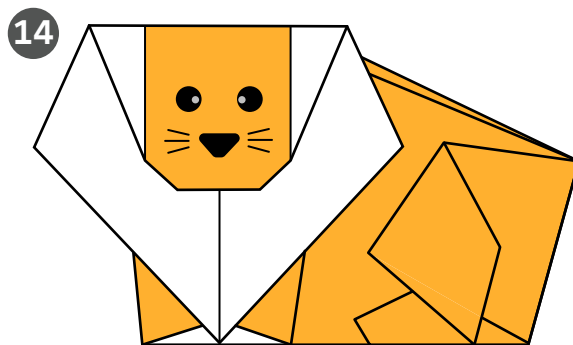
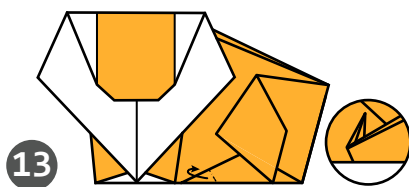
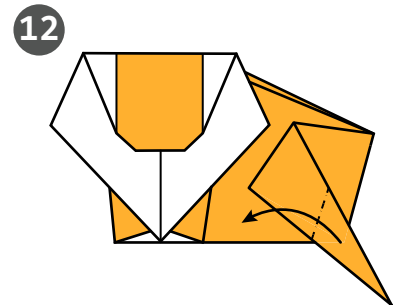
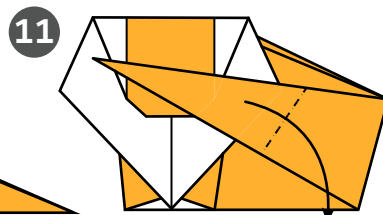
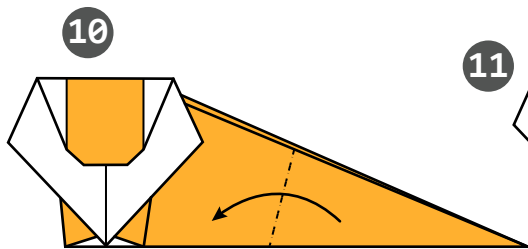
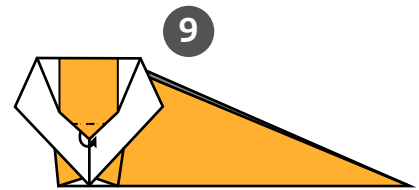
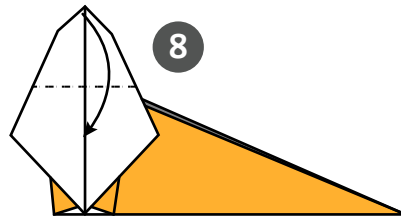
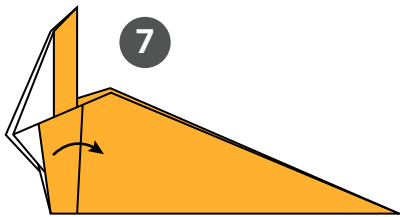
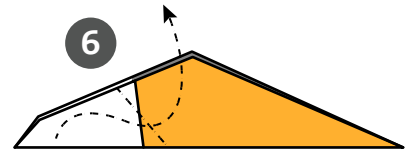
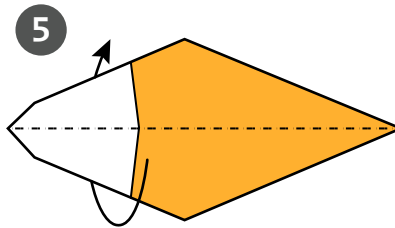
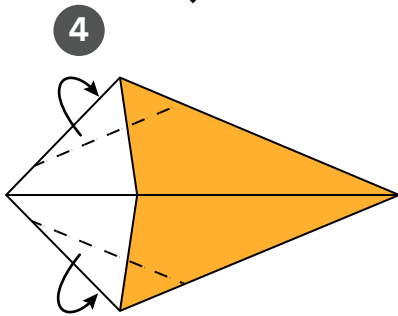
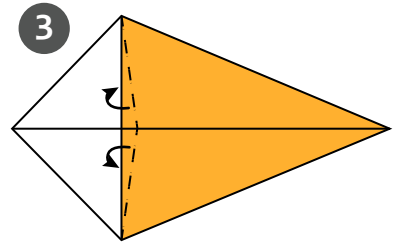
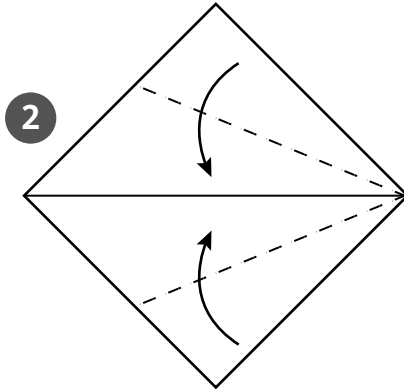
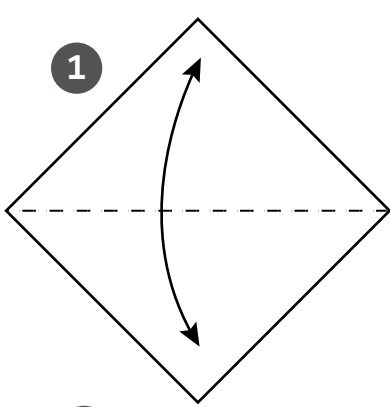

# TORTUE: ★★☆☆☆

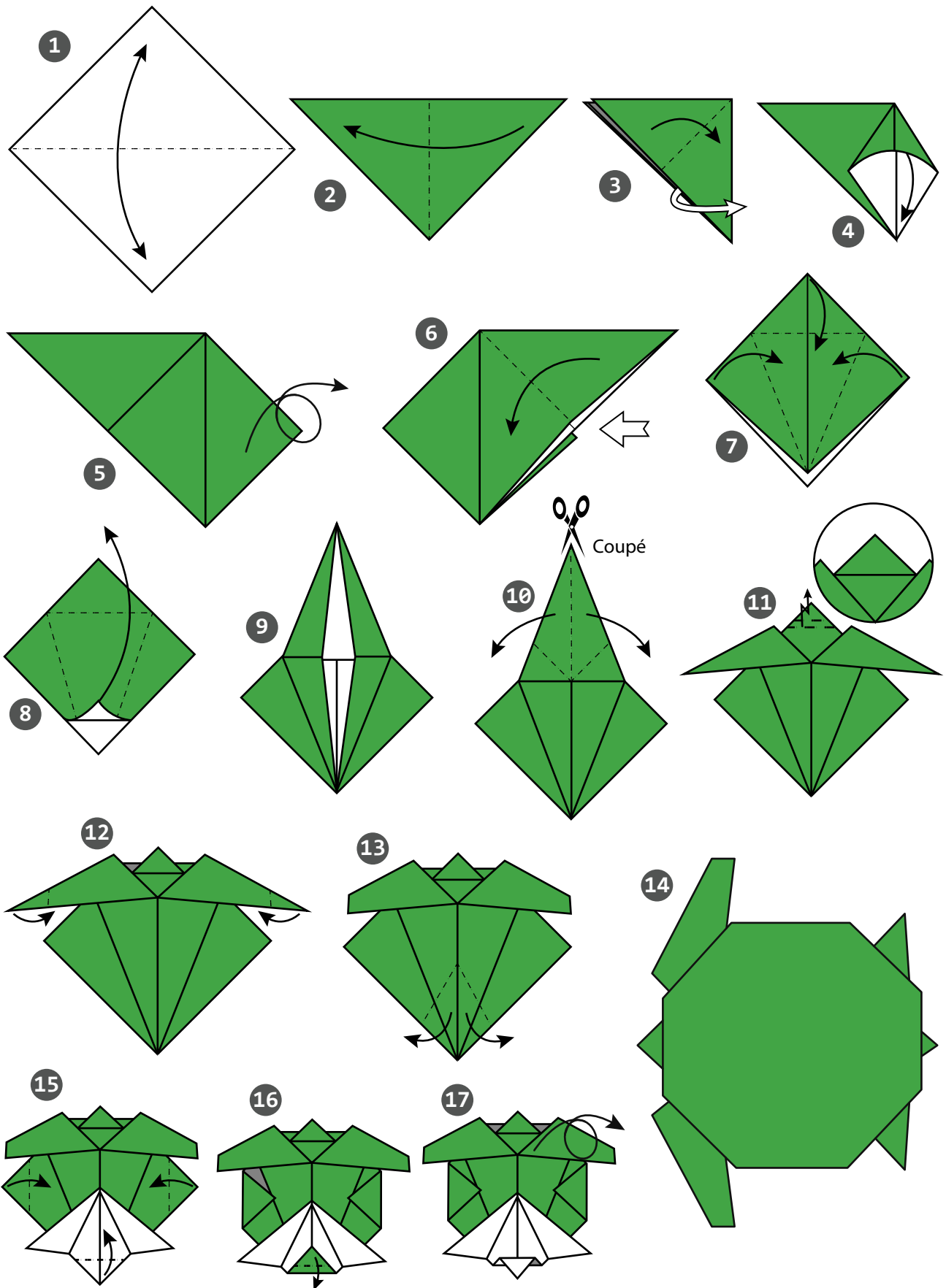

# GRUE TRADITIONNEL : ★★☆☆☆

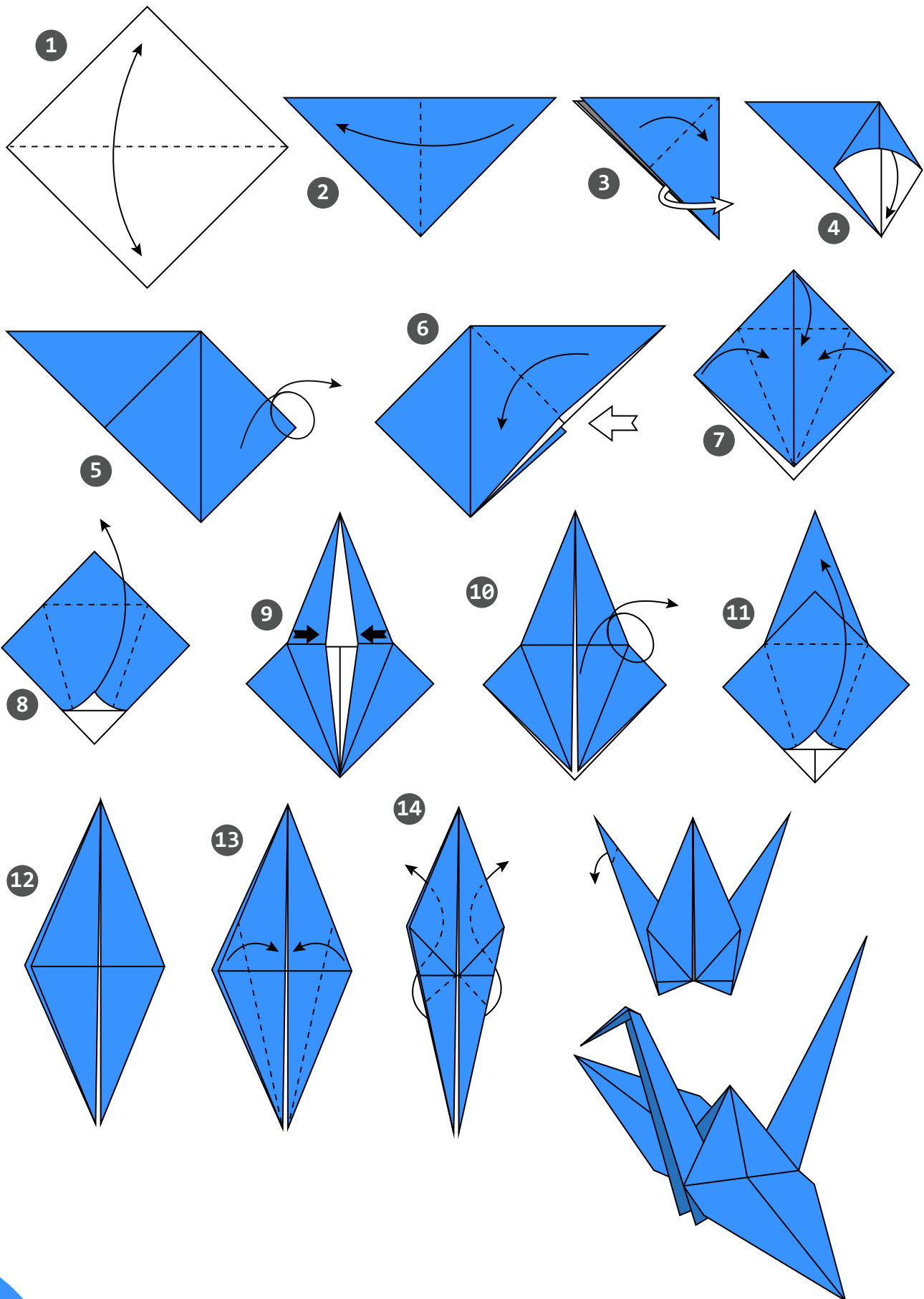

# Bebé Dinausore

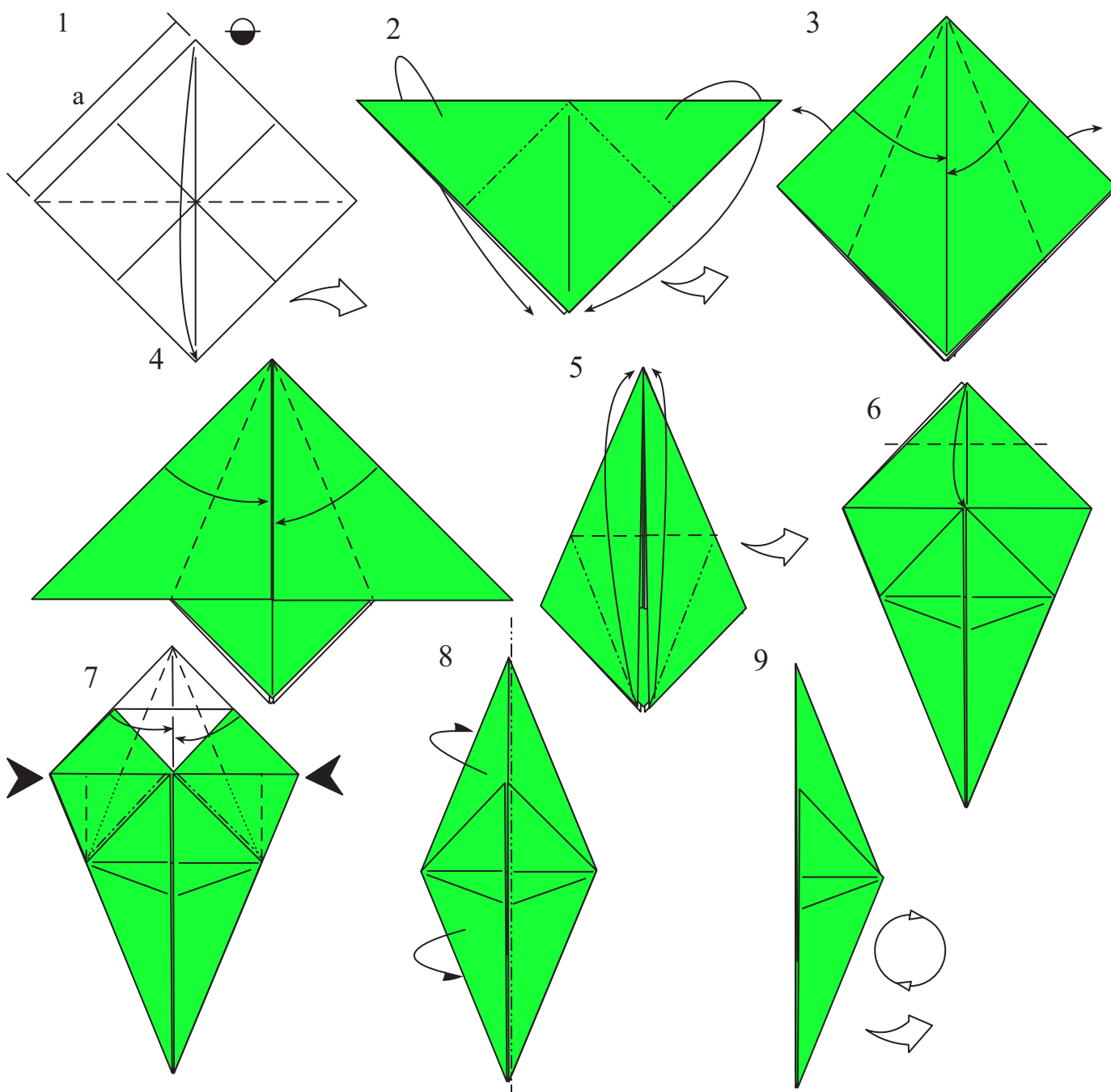
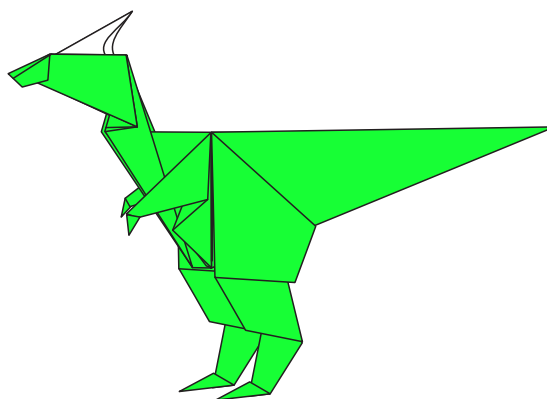

10

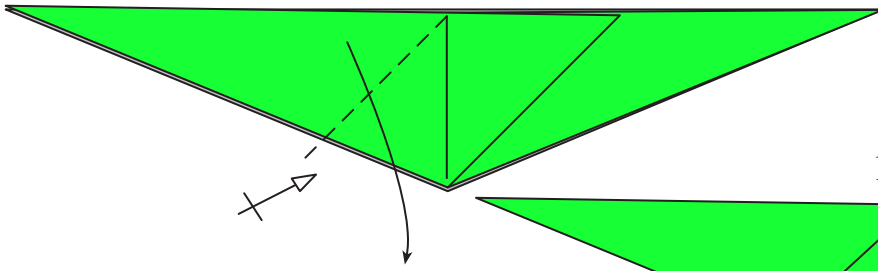

11

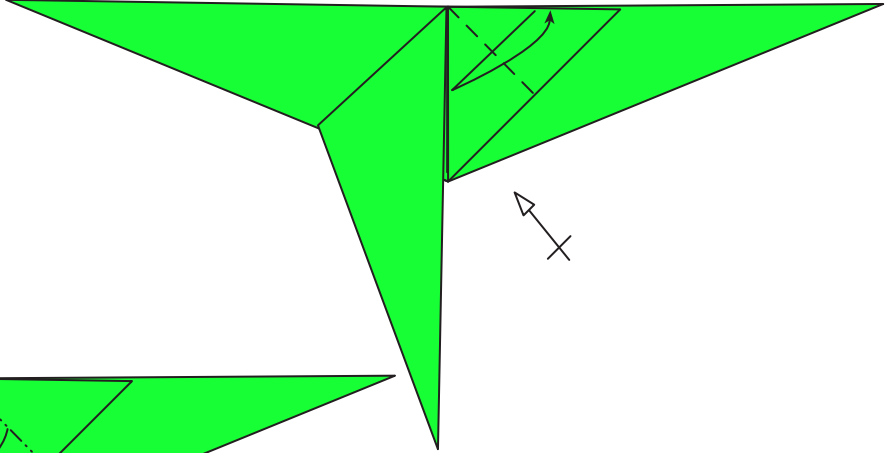

12

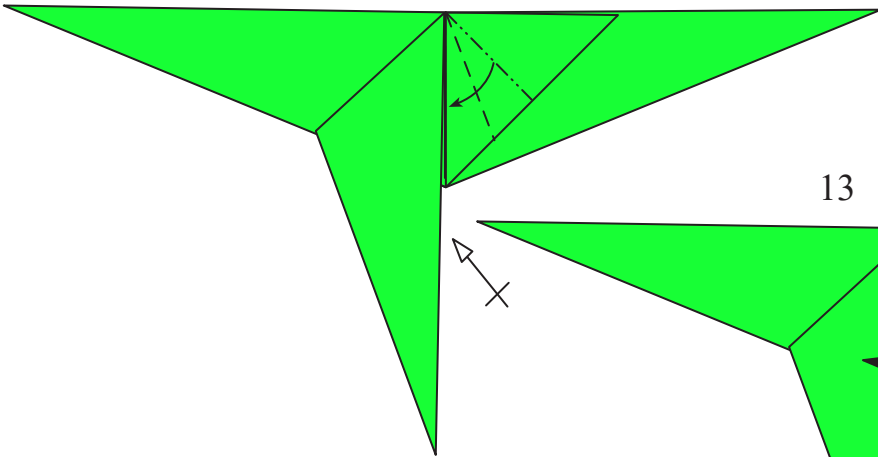

13

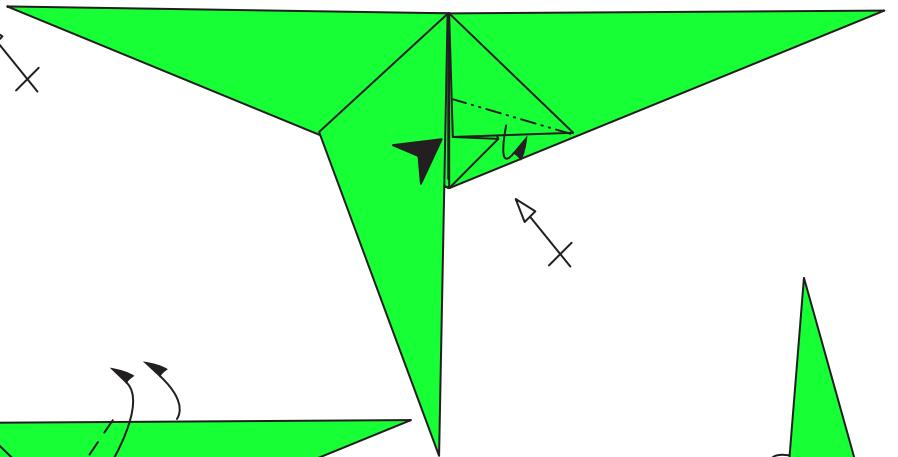

14

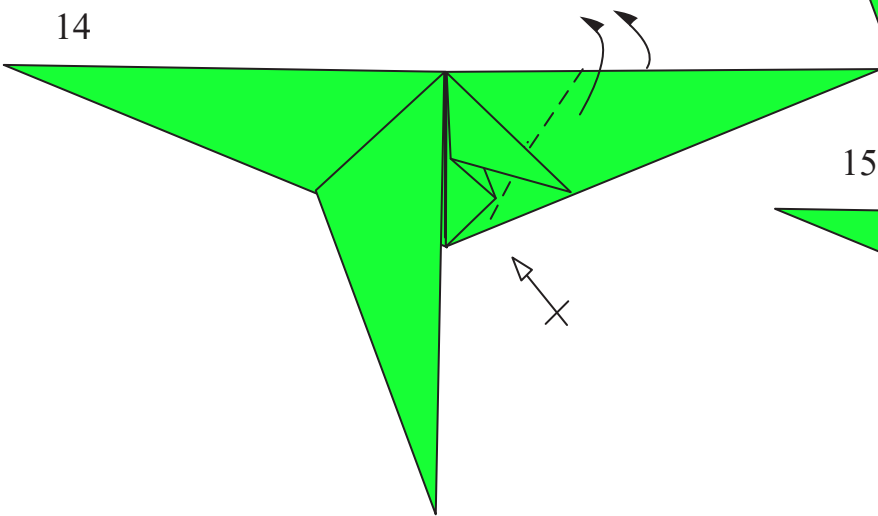

15

